

BID DOCUMENTS
FOR
2021 Street Program – Contract 1



CITY OF OWOSSO
301 W. MAIN STREET
OWOSSO, MICHIGAN 48867

June 10, 2021

**NOTICE TO BIDDERS
2021 STREET PROGRAM – CONTRACT 1
FOR THE CITY OF OWOSSO, MICHIGAN**

Sealed proposals will be received by the city of Owosso for the

2021 STREET PROGRAM – CONTRACT 1

and should be addressed to:

Bid Coordinator
City of Owosso
301 W. Main Street
Owosso, Michigan 48867

Major items include: HMA paving, HMA base crush and shape, asphalt stabilized base course, including storm sewer construction within the city of Owosso.

Bids will be accepted until **3:00 p.m. Tuesday, July 6, 2021** for the **2021 Street Program – Contract 1** at which time bids will be publicly opened and read aloud. This bid will be considered “All or None”.

“All or None” means that bidders are required to submit pricing for all items requested. Any proposal received that does not meet this requirement will be disqualified. If said bid is not listed as “All or None” the City reserves the right to split said bid to our best benefit.

All bids must be in writing and must contain an original signature by an authorized officer of the firm. Electronic bids (i.e., telephonic, fax, email, etc.) are **NOT** acceptable.

All bids must be accompanied by a Bid Bond for 5% of the total bid and shall be made payable to the city of Owosso. This amount shall be forfeited in the case of failure on the part of the successful bidder to sign a contract and furnish satisfactory bonds as required within ten (10) consecutive calendar days after the acceptance of the bid by the city of Owosso.

The bidder agrees that if the city accepts their proposal, the bidder will, within 10 consecutive calendar days after receiving notice of this acceptance, enter into a contract to furnish all labor, equipment and tools necessary to execute the work at the unit prices named in the bid proposal and will furnish the surety for performance, for one hundred percent (100%) of this bid, which shall be accepted and approved by the city.

All bids shall clearly contain on the outside of the **sealed** envelope in which they are submitted:

2021 STREET PROGRAM – CONTRACT 1

Hard copies of the proposal, contract forms and specifications are on file and may be obtained for a fee in accordance with the city's FOIA Policy at the office of the Bid Coordinator, City Hall, 301 West Main Street, Owosso, Michigan 48867. Bid documents are available at no charge on our website at www.ci.owosso.mi.us or on the MITN website at www.mitn.info.

The city reserves the right to accept any proposal; or to reject any proposal; to waive irregularities in a proposal; or to negotiate if it appears to be in the best interest of the city of Owosso.

No work can begin before August 16, 2021 and all work is to be completed by October 29, 2021.

INQUIRIES/ADDENDUMS

Addendums will be available on the city's website at www.ci.owosso.mi.us and on the MITN website at www.mitn.info.

All inquiries regarding this bid request must be submitted to Randy Chesney, PE and received at least seven (7) calendar days prior to the submission and shall be received in, and responded to, in writing, or via FAX at 989-723-8854 or by e-mail to: randy.chesney@ci.owosso.mi.us , Call 989-725-0504 to arrange a field inspection.

INSTRUCTIONS TO BIDDERS

1. Each proposal must be signed by the bidder with his usual signature. Bids by partnerships should be signed with the partnership name by one of the members of the partnership or by an authorized representative, followed by the signature and title of the person signing. Proposals by corporations must be signed with the name of the corporation, followed by the signature and designation of the president, vice-president or person authorized to bind it in the matter. **Any paperwork not filled out properly or signed will cause the bid to be considered non-responsive and shall be rejected by the city.**
2. Proposals, to receive consideration, must be received prior to the specified time of opening and reading as designated in the invitation.
3. Bidders are requested to use the proposal form furnished by the city when submitting their proposals. Envelopes must be **sealed** when submitted and clearly marked on the outside indicating the name of the bid.
4. Proposals having and erasures or corrections thereon may be rejected unless explained or noted over the signature of the bidder.
5. References in the specifications or description of materials, supplies, equipment, or services to a particular trade name, manufacturer's catalog, or model number are made for descriptive purposes to guide the bidder in interpreting the type of materials or supplies, equipment, or nature of the work desired. They should not be construed as excluding proposals on equivalent types of materials, supplies, and equipment or for performing the work in a manner other than specified. However, the bidders' attention is called to General Condition seven (7).
6. Proposals should be mailed or delivered to: Bid Coordinator's Office, City Hall, 301 W. Main Street, Owosso, MI 48867.
7. Special conditions included in this inquiry shall take precedence over any conditions listed under General Conditions or Instructions to Bidders.
8. Insurance coverage – The winning bidder, prior to execution of the contract, shall file with the city copies of completed certificates of insurance naming the city of Owosso as an additional insured party, as evidence that the contractor carries adequate insurance satisfactory to the city.
9. The city of Owosso has a local preference policy for the purchase of goods and services. The policy in part states: *A business located within the city limits and paying real or personal property taxes to the city of Owosso will be granted a six percent (6%) bid advantage or \$2,500, whichever is less, over a business located outside Shiawassee County. A business located outside the city limits but within Shiawassee County and paying property taxes to the county will be granted a three percent (3%) bid advantage or \$2,500, whichever is less, over a business located outside Shiawassee County. The preference also applies to subcontractors performing twenty-five percent (25%) or more of the work of a general contract.*
10. **The following items must be included with the bid response:**
 - a. **Vendor Proposal**
 - b. **Local Preference Affidavit**
 - c. **W-9 Request for Taxpayer ID No. and Certification**
 - d. **Signature Page & Legal Status/ Acknowledgement of Addendum(s)**
 - e. **Insurance Endorsement**

Bid Proposal

2021 STREET PROGRAM – CONTRACT 1

TO: THE CITY OF OWOSSO (HEREINAFTER CALLED THE “CITY”)

Bidder must provide pricing for each item listed. If additional pricing elements are being offered by the bidder, they are to be listed under “other services/items offered.”

The undersigned, having examined the bid proposal forms and specifications, does hereby offer to **2021 STREET PROGRAM – CONTRACT 1** from **August 16, 2021** through **October 29, 2021** listed below at the following prices to wit:

Road and Storm Sewer (Bid Items 1-58):

Item	Description	Approx. Quantity	Unit	Unit Price	Total Price
1	Mobilization, Max \$55,700 (Road, Storm, and Sanitary)	1	LSUM		
2	Culv, Rem, Less than 24 inch	4	Ea		
3	Curb and Gutter, Rem	26	Ft		
4	Pavt, Rem	1426	Syd		
5	Sidewalk, Rem	46	Syd		
6	Embankment, CIP	132	Cyd		
7	Excavation, Earth	587	Cyd		
8	Subgrade Undercutting, Special	300	Syd		
9	Erosion Control, Inlet Protection, Fabric Drop	19	Ea		
10	Subbase, CIP	45	Cyd		

Item	Description	Approx. Quantity	Unit	Unit Price	Total Price
11	Aggregate Base, LM, Modified	25	Cyd		
12	Aggregate Base, 8 inch, Modified	653	Syd		
13	Aggregate Base, 9 inch, Modified	1551	Syd		
14	Aggregate Base, 10 inch, Modified	234	Syd		
15	HMA Base Crushing and Shaping, Modified	10,146	Syd		
16	Material, Surplus and Unsuitable, Rem, LM	25	Cyd		
17	Salv Crushed Material, LM	10	Cyd		
18	Asphalt Cement Stabilized Base, Modified	10,146	Syd		
19	Asphalt Cement Binder	16,229	Gal		
20	Trenching, Modified	60	Sta		
21	Maintenance Gravel	100	Ton		
22	Approach, CI I, LM	124	Cyd		
23	Shoulder, CI I	68	Ton		
24	Geotextile, Separator, Modified	801	Syd		

Item	Description	Approx. Quantity	Unit	Unit Price	Total Price
25	Culv End Sect, Conc, 12 inch	5	Ea		
26	Culv, Cl E, Conc, 12 inch	250	Ft		
27	Sewer, SDR-26, 10 inch, Tr Det B, Modified	147	Ft		
28	Sewer, SDR-26, 12 inch, Tr Det B, Modified	78	Ft		
29	Sanitary Service, Conflict	5	Ea		
30	Abandoned Gas main, Conflict	5	Ea		
31	Dr Structure Cover, Adj, Case 1	19	Ea		
32	Dr Structure, Adj, Add Depth	3	Ft		
33	Dr Structure Cover, EJ 1040 w/ Vented Cover	4	Ea		
34	Dr Structure Cover, EJ 1040 w/ Solid Gasket Sealed Cover	10	Ea		
35	Dr Structure Cover, EJ 1040 w/ Type O2 Beehive Grate	10	Ea		
36	Dr Structure, 36 inch dia, Modified	3	Ea		
37	Dr Structure, 48 inch dia, Modified	2	Ea		
38	Dr Structure, Tap, 10 inch	1	Ea		

Item	Description	Approx. Quantity	Unit	Unit Price	Total Price
39	Dr Structure, Temp Lowering	12	Ea		
40	Cold Milling HMA Surface	953	Syd		
41	HMA, 13A	2858	Ton		
42	Cement	2	Ton		
43	Driveway, Nonreinf Conc, 6 inch	79	Syd		
44	Driveway, Nonreinf Conc, 7 inch	37	Syd		
45	Driveway, Nonreinf Conc, 9 inch	255	Syd		
46	Curb and Gutter, Conc, Det F4, Modified	26	Ft		
47	Sidewalk, Conc, 6 inch	499	Sft		
48	Barricade, Type III, High Intensity, Double Sided, Furn & Oper	9	Ea		
49	Minor Traf Devices, Max \$10,000	1	LSUM		
50	Plastic Drum, Fluorescent, Furn & Oper	25	Ea		
51	Sign, Type B, Temp, Prismatic, Furn & Oper	523	Sft		
52	Pedestrian Type II Barricade, Temp	5	Ea		

Item	Description	Approx. Quantity	Unit	Unit Price	Total Price
53	Turf Establishment, Performance	3865	Syd		
54	Gate Box, Adj, Case 1	1	Ea		
55	Post, Steel, 3 lb	80	Ft		
56	Sign, Type III, Erect, Salv	5	Ea		
57	Sign, Type III, Rem	5	Ea		
58	Post, Mailbox	27	Ea		

Bidder's Initial _____

BID TOTAL

Total of all Road and Storm Sewer (Bid Items 1-58)

(use words)

\$

(use figures)

Bidder's Initial _____

VARIANCE FROM SPECIFICATIONS: If the bidder is unable to comply with the specifications as outlined, the bidder shall clearly note these variations from the specifications. The bidder may also propose additions to these specifications for the city to consider, but the costs associated with these additions shall be stated separately.

If the work is not complete on or before the date set for completion or any extension, the Contractor shall pay the city liquidated damages of **\$900.00** a calendar day until the work is satisfactorily completed. Liquidated damages for delay may be deducted from payments due the contractor or may be collected from the Contractor or the Contractor's surety.

The undersigned agrees that if the city accepts this proposal, Contractor will, within 10 consecutive calendar days after receiving notice of this acceptance, enter into a contract to furnish all labor, equipment and tools necessary to execute the work at the unit prices named in the bid proposal. Contractor will furnish the surety for performance, for 100% of this bid, which shall be accepted and approved by the city.

The undersigned agrees that if the city accepts this proposal, Contractor will start this project no sooner than **August 16, 2021** and will substantially complete the entire work under this contract by **October 29, 2021**. This schedule may be extended for rain days or cold weather for calendar days after **October 29, 2021**, only as approved by the city of Owosso.

On behalf of _____, I hereby submit this proposal for **2021 STREET PROGRAM – CONTRACT 1** for your consideration. The undersigned acknowledges that this proposal is subject to the General Conditions and the General Specifications included in the contract documents. In submitting this proposal, it is understood that the right is reserved by the CITY to reject any and all proposals, and waive any irregularities in the bidding process. The CITY may award this contract based on any combination of the total bid and/or alternates.

Dated and signed at _____ State of _____

This _____ day of _____, 20____.

Bidder

Witness:

By/s/

Business Address

Signature

Printed Name

Title

Telephone Number

E-Mail Address

GENERAL CONDITIONS

1. LOCAL PREFERENCE POLICY

The city of Owosso has a local preference policy for the purchase of goods and services. The policy in part states: *A business located within the city limits and paying real or personal property taxes to the city of Owosso will be granted a 6% bid advantage or \$2,500, whichever is less, over a business located outside Shiawassee County. A business located outside the city limits but within Shiawassee County and paying property taxes to the county will be granted a 3% bid advantage or \$2,500, whichever is less, over a business located outside Shiawassee County. The preference also applies to subcontractors performing 25% or more of the work of a general contract.*

2. BID ACCEPTANCE

The city reserves the right to reject any or all proposals. Unless otherwise specified, the city reserves the right to accept any item in the proposal. In case of error in extending the total amount of the bid, the unit prices shall govern. The city objects to any additional terms stated in any documents submitted by the contractor. Performance pursuant to our Purchase Order/Equipment Agreement constitutes a course of conduct consisting of Contractor's Agreement to the terms of our Purchase Order/Equipment Agreement.

3. PAYMENT

Unless otherwise stated by the bidder, time, concerning discount offered, will be computed from date of delivery and acceptance at destination or from date correct bill or claim voucher properly certified by the contractor is received. When so stated herein, partial payments, based on a certified approved estimate by the city of materials, supplies or equipment delivered or work done, may be made upon presentation of a properly-executed claim voucher. The final payment will be made by the city when materials, supplies, equipment or the work done have been fully delivered or completed to the full satisfaction of the city.

4. BID DEFAULT

In case of default by the bidder or contractor, the city of Owosso may procure the articles or services from other sources and hold the bidder or contractor responsible for any excess cost occasioned thereby.

5. UNIT PRICES

Prices should be stated in units of quantity specified.

6. QUOTED PRICES

Unless otherwise stated by the bidder, prices quoted will be considered as being based on delivery to a designated destination and to include all charges for packing, crating, containers, shipping, etc., and being in strict accordance with specifications and standards as shown.

7. SUBSTITUTIONS

Wherever a reference is made in the specifications or description of the materials, supplies, equipment, or services required, to a particular trade name, manufacturer's catalog, or model number, the bidder, if awarded a contract or order, will be required to furnish the particular item referred to in strict accordance with the specifications or description unless a departure or substitution is clearly noted and described in the proposal.

8. HOLD CITY HARMLESS

The bidder, if awarded an order or contract, agrees to protect, defend, and save the city harmless against any demand for payment for the use of any patented material, process, article, or device that may enter into the manufacture, construction, or form a part of the work covered by either order or contract. Bidder further agrees to indemnify and save the city harmless from suits or action of every nature and description

brought against it, for or on account of any injuries or damages received or sustained by any party or parties, by or from any of the acts of the contractor, his employees, subcontractors, or agents.

9. COMPETITIVE BIDDING STATUTES

The laws of the state of Michigan, the charter and ordinances of the city of Owosso, as far as they apply to the laws of competitive bidding, contracts and purchases, are made a part hereof.

10. SAMPLES

Samples, when requested, must be furnished free of expense to the city and, if not destroyed, will upon request be returned at the bidder' expense.

11. BONDS

A certified check or bid bond may be required, payable to the City of Owosso. If so required in the bid documents, a performance bond and labor and material bond in the amounts stated in the bid documents, shall be on file with the city before work commences. The city will determine the amount and sufficiency of the sureties.

12. PROPOSAL GUARANTEE

All checks or bid bonds, except those of the three lowest bidders, will be returned when the bids have been opened and tabulated. The certified checks or bid bonds of the three lowest bidders will be held until the contract documents have been signed, after which remaining certified checks or bid bonds will be returned to the respective bidders.

13. BIDDERS

The city may demand that the contractor file a sworn experience and financial statement setting forth the financial resources, adequacy of plant and equipment, organization, experience and other pertinent and material facts as may be desirable.

14. INSURANCE AND HOLD HARMLESS

To the fullest extent permitted by law the Contractor agrees to defend, pay on behalf of, indemnify, and hold harmless the City of Owosso, its elected and appointed officials, employees, agents and volunteers, and others working on behalf of the City of Owosso against any and all claims, demands, suits, or loss, including all costs connected therewith, and for any damages which may be asserted, claimed, or recovered against or from the City of Owosso, by reason of personal injury, including bodily injury or death and/or property damage, including loss of use thereof, for all actions of the Contractor.

Contractor shall not commence work under this contract until they have obtained the insurance required under this paragraph, and shall keep such insurance in force during the entire life of this contract. All coverage shall be with insurance companies licensed and admitted to do business in the State of Michigan and acceptable to the City of Owosso. The requirements below should not be interpreted to limit the liability of Contractor. All deductibles and SIR's are the responsibility of Contractor. Contractor shall procure and maintain the following insurance coverage:

- a. Worker's Compensation Insurance including Employers' Liability Coverage, in accordance with all applicable statutes of the State of Michigan.
- b. Commercial General Liability Insurance on an "Occurrence Basis" with limits of liability not less than \$1,000,000 per occurrence and aggregate. Coverage shall include the following extensions: (A) Contractual Liability; (B) Products and Completed Operations; (C) Independent Contractors

Coverage; (D) Broad Form General Liability Extensions or equivalent, if not already included. (E) Explosion, Collapse, and Underground (XCU) coverage, if applicable. Limits may be obtained by the use of primary and excess/umbrella liability policies.

- c. Automobile Liability including Michigan No-Fault Coverages, with limits of liability not less than \$1,000,000 per occurrence, combined single limit for Bodily Injury, and Property Damage. Coverage shall include all owned vehicles, all non-owned vehicles, and all hired vehicles.
- d. Owners' and Contractor Protective Liability: The Contractor shall procure and maintain during the life of this contract, a separate Owners' and Contractor's Protective Liability Policy with limits of liability not less than \$1,000,000 per occurrence and aggregate for Personal Injury, Bodily Injury, and Property Damage. The City of Owosso shall be the "Named Insured" on said coverage.
- e. Additional Insured: Commercial General Liability and Automobile Liability as described above shall include an endorsement stating the City of Owosso shall be listed as additional insured. It is understood and agreed by naming the City of Owosso as additional insured, coverage afforded is considered to be primary and any other insurance the City of Owosso may have in effect shall be considered secondary and/or excess.
- f. Cancellation Notice: All policies, as described above, shall include an endorsement stating that it is understood and agreed Thirty (30) days, Ten (10) days for non-payment of premium, Advance Written Notice of Cancellation, shall be sent to: **(The City of Owosso, Debbie Hebert, Insurance Coordinator, 301 W. Main Street, Owosso, MI 48867).**
- g. Proof of Insurance Coverage: Contractor shall provide the City of Owosso at the time that the contracts are returned by him/her for execution, a Certificate of Insurance as well as the required endorsements. In lieu of required endorsements, if applicable, a copy of the policy sections where coverage is provided for additional insured and cancellation notice would be acceptable.

If any of the above coverages expire during the term of this contract, the Contractor shall deliver renewal certificates and endorsements to the City of Owosso at least ten (10) days prior to the expiration date.

15. PROTECTION OF LAND MONUMENTS AND PROPERTY STAKES

Land monuments or stakes marking property corners shall not be moved or otherwise disturbed except as directed by the city. If any land monuments or lot stakes are moved or disturbed by the contractor, the cost of replacing each land monument or lot stake so moved or disturbed shall be deducted from any money due the contractor, as payment to the city for the cost of replacing said land monument or lot stakes.

16. CONTRACTOR'S RESPONSIBILITY FOR WORK

The contractor shall be responsible for any damages that the work may sustain before its acceptance, and shall rebuild, repair, restore and make good, at its own expense, all injuries and damages to any portion of the work by the action of the elements or from any cause whatsoever before its acceptance. Neither the final payment nor any provision in the contract documents shall relieve the contractor of the responsibility for negligence or faulty materials or workmanship within the extent and period provided by law, and, upon written notice, the contractor shall remove any defects due therefrom and pay for any damaged due to other work resulting therefrom, which shall appear within one year after the date of completion and acceptance.

17. PAYMENT

At monthly intervals commencing after construction has been started, the city will make partial payment to the contractor based on a duly-certified estimate prepared by the city of the work done by the contractor during the preceding four-week period. Each estimate will be submitted to the city council for approval on either the first or third Monday of each month. The city will retain ten percent (10%) of the amount of each such estimate until final completion and acceptance of all work covered by this contract. Before the contractor shall demand final estimates or payment, contractor will furnish to the city, supported by sworn statements, satisfactory evidence that all persons that have supplied labor, materials, or equipment for the work embraced under this contract have been fully paid for the same; and that, in case such evidence be not furnished as aforesaid, such sums as the city may deem necessary to meet the lawful claims of such persons may be retained by the city from any monies that may be due or become due to the contractor under this contract until such liabilities shall be fully discharged and the evidence thereof be furnished to the city.

18. CITY'S RIGHT TO WITHHOLD CERTAIN AMOUNTS AND MAKE APPLICATION THEREOF

Besides the payment to be retained by the city under the preceding provisions of these general conditions, the city may withhold a sufficient amount of any payment otherwise due to the contractor to cover a) payments earned or due for just claims for furnish labor or materials on the project under this contract, b) for defective work not remedied and c) for failure of the contractor to make proper payments to subcontractors. The city shall disburse and shall have the right to act as agent for the contractor in disbursing such funds as have been previously withheld pursuant to this paragraph to the party or parties who are entitled to payment from it. The city will pay to the contractor a proper accounting of all such funds disbursed for the contractor.

19. OWNER'S RIGHT TO DO WORK

If the contractor should neglect to prosecute the work properly or fail to perform any provisions of this contract, the city, after three (3) days' written notice to the contractor and contractor's surety, may without prejudice to any other remedy he may have, make good such deficiencies and may deduct the cost of it from the payment due the contractor.

20. DEFINITION OF NOTICE

Where in any of the contract documents there is any provision in respect to the giving of notice, such notice shall be deemed given to the owner, when written notice is delivered to the city manager, or placed in the United States mail addressed to the city clerk; as to the contractor, when a written notice shall be delivered to contractor's representative at the project site or by mailing such written notice in the United States mail addressed to the contractor at the place stated in the bid proposal as the business address; as to the surety on the performance bond, when a written notice is placed in the United States mail addressed to the surety at the surety's home office or to its agent or agents who executed such performance bond on behalf of the surety.

21. SUBCONTRACTS

The contractor shall not subcontract any work in the execution of this contract without the written consent of the city. The contractor shall be responsible for the acts or omissions of any subcontractor and of anyone employed directly or indirectly by such subcontractor.

22. ASSIGNMENT OF CONTRACT

The contractor shall not assign this contract or any part hereof without the written consent of the city. No assignment shall be valid unless it shall contain a provision that any funds to be paid to the assignee under this agreement are subject to a prior lien for services rendered or materials or supplies for the performance of the work specified in the contract in favor of all persons, firms, or corporations rendering such services or supplying such materials.

23. MAINTAINING TRAFFIC

The contractor shall provide flares, signs, barricades, traffic regulators, etc., to conform to the current *Michigan Manual of Uniform Traffic Control Devices* or as directed by the city. The contractor shall not close any road or street without the permission of the city. If any street or road is to be closed by the contractor, it shall be the responsibility of the contractor to notify the Owosso fire department when the street will be closed and again when the street is open to traffic. Traffic control devices for any detours deemed necessary by the city shall be provided by the contractor. Cost of maintaining shall be incidental to the cost of the project unless otherwise provided.

24. ORDER OF COMPLETION

The contractor shall submit, whenever requested by the city, a schedule of the work showing completion dates. The city may request that certain portions of the work be done before other portions. If so requested, the contractor shall arrange to schedule to meet the request by the owner.

25. USE OF COMPLETED PORTIONS

The city shall have the right to take possession and use any completed or partially completed portions of the work; but such taking possession and use shall not be deemed acceptance. Pending final completion and acceptance of the work, all necessary repairs and adjustments on any section of the work due to defective material, workmanship, natural causes, or other operations of the contractor, other than normal wear and tear, shall be done by and at the expense of the contractor.

26. WATER SUPPLY

The contractor shall secure an adequate water supply for use in construction and for drinking water for his employees. If the city's water is used on the work, the contractor shall make the necessary application and shall pay all costs involved. Connections, piping and fittings for conveying water shall be furnished and maintained by the contractor. Contractor shall pay for water according to the city's established rates.

27. CLEANUP

The contractor shall keep the project free from waste materials or rubbish caused by its employees or work. This includes as a minimum excess excavation or backfill material, broken or rejected materials, empty containers or general debris. The owner may require complete cleanup of certain areas as construction is completed.

28. SUPERVISION

The contractor shall have a superintendent on the job site to coordinate and expedite the various construction activities for the duration of this contract.

29. EQUAL EMPLOYMENT OPPORTUNITY AND OTHER CLAUSES

The contractor shall agree not to discriminate against any employee or applicant for employment because of age, race, religion, color, handicap, sex, physical condition, developmental disability as defined by Michigan Compiled Statutes, or national origin. This provision shall include but not be limited to the following: employment, upgrading, demotion or transfer, recruitment or recruitment advertising, layoff or termination, rate of pay or other forms of compensation, and selection for training including apprenticeship. The contractor further agrees to take affirmative action to ensure equal employment opportunities for persons with disabilities. The contractor agrees to post in conspicuous places, available to employees and applicants for employment, notices setting forth the provision of the non-discrimination clause.

LOCAL PREFERENCE POLICY

The following affidavit should be completed if a bidder is located within Shiawassee County or intends to sub-contract more than twenty-five percent (25%) to a Shiawassee County based business: The city of Owosso has a local preference policy for the purchase of goods and services as recorded in the city ordinance in section 2-348. "Lowest qualified bidder" defined.

1. The term "lowest qualified bidder," as used in this division, shall mean the lowest bidder having qualifications to perform the work which are satisfactory to the council. The lowest bidder shall be determined based on an adjusted bid tabulation which shall be prepared in the following manner: To the bid of any bidder which is neither a city-based business nor a county-based business shall be added an amount equal to six (6) percent of the bid or two thousand five hundred dollars (\$2,500.00), whichever is less.
2. To the bid of any bidder which is a county-based business shall be added an amount equal to three (3) percent of the bid or two thousand five hundred dollars (\$2,500.00), whichever is less; provided, however, that if no bid is received from a city-based business, no additional amount shall be added to the bid of a county-based business.
3. "Owosso-based business" shall be interpreted to mean a business registered with the county clerk or a corporation registered with the state having a business address within the city limits which pays real and/or personal property taxes levied by the city.

The term "county-based business" shall be interpreted to mean a business other than a city-based business registered with the county clerk or a corporation registered with the state having a business address within the county which pays real and/or personal property taxes levied by the county.

4. If twenty-five (25) percent or more of a contract for construction or other services is to be subcontracted by a city-based business bidder to a non-city-based business or businesses, or by a county-based business bidder to a non-county-based business or businesses, the adjusted bid shall be calculated by applying the provisions of this section separately to each portion of the contract based on the status of the contractor or subcontractor performing that portion of the contract as a city-based or county-based business.

AFFIDAVIT

In accordance with Section 2-348 of the Owosso city code, the bid from a business located in Shiawassee County shall be adjusted to reflect a preference. In order for the city to calculate the adjustment, the bidder hereby deposes and states that their business address is registered, and is currently paying real and/or personal property taxes in Shiawassee County at the following address:

Registered business address

The affiant further deposes and states that a sub-contract with a business registered, and paying real and/or personal property taxes in Shiawassee County will be executed for a percentage equal to or greater than twenty-five percent (25%) as stated below:

Business name and address of sub-contractor

Percentage of contract

Authorized signature

Date

Title

Company name

SIGNATURE PAGE AND LEGAL STATUS

The undersigned certifies that he is an official legally authorized to bind his firm and to enter into a contract should the city accept this proposal.

Bid proposal by _____
(Name of Firm)

Legal status of bidder. Please check the appropriate box and **USE CORRECT LEGAL NAME.**

A. Corporation ____ ; State of Incorporation _____

B. Partnership ____ ; List of names _____

C. DBA ____ ; State full name _____ DBA

D. Other ____ ; Explain _____

Signature of Bidder _____ Title _____
(Authorized Signature)

Printed name _____

Signature of Bidder _____ Title _____
(Authorized Signature)

Printed name _____

Address _____ City _____ Zip _____

Telephone () _____

Signed this _____ day of _____ 20____.

Bidder acknowledges receipt of the following Addenda:

ADDENDUM NO.	BIDDER'S INITIALS
_____	_____
_____	_____
_____	_____

W-9 INFORMATION FOR LEGAL STATUS

Sole proprietor. Enter your individual name as shown on your income tax return on the “Name” line. You may enter your business, trade, or “doing business as (DBA)” name on the “Business name/disregarded entity name” line.

Partnership, C Corporation, or S Corporation. Enter the entity's name on the “Name” line and any business, trade, or “doing business as (DBA) name” on the “Business name/disregarded entity name” line.

Disregarded entity. Enter the owner's name on the “Name” line. The name of the entity entered on the “Name” line should never be a disregarded entity. The name on the “Name” line must be the name shown on the income tax return on which the income will be reported. For example, if a foreign LLC that is treated as a disregarded entity for U.S. federal tax purposes has a domestic owner, the domestic owner's name is required to be provided on the “Name” line. If the direct owner of the entity is also a disregarded entity, enter the first owner that is not disregarded for federal tax purposes. Enter the disregarded entity's name on the “Business name/disregarded entity name” line. If the owner of the disregarded entity is a foreign person, you must complete an appropriate Form W-8.

Note. Check the appropriate box for the federal tax classification of the person whose name is entered on the “Name” line (Individual/sole proprietor, Partnership, C Corporation, S Corporation, Trust/estate).

Limited Liability Company (LLC). If the person identified on the “Name” line is an LLC, check the “Limited liability company” box only and enter the appropriate code for the tax classification in the space provided. If you are an LLC that is treated as a partnership for federal tax purposes, enter “P” for partnership. If you are an LLC that has filed a Form 8832 or a Form 2553 to be taxed as a corporation, enter “C” for C corporation or “S” for S corporation. If you are an LLC that is disregarded as an entity separate from its owner under Regulation section 301.7701-3 (except for employment and excise tax), do not check the LLC box unless the owner of the LLC (required to be identified on the “Name” line) is another LLC that is not disregarded for federal tax purposes. If the LLC is disregarded as an entity separate from its owner, enter the appropriate tax classification of the owner identified on the “Name” line.

Other entities. Enter your business name as shown on required federal tax documents on the “Name” line. This name should match the name shown on the charter or other legal document creating the entity. You may enter any business, trade, or DBA name on the “Business name/disregarded entity name” line.

Please see attached W-9 Request for Taxpayer Identification Number and Certification form for a detailed explanation on filling out the W-9 form.

Request for Taxpayer Identification Number and Certification

**Give Form to the
requester. Do not
send to the IRS.**

▶ Go to www.irs.gov/FormW9 for instructions and the latest information.

Print or type. See Specific Instructions on page 3.	1	Name (as shown on your income tax return). Name is required on this line; do not leave this line blank.		
	2	Business name/disregarded entity name, if different from above		
	3	Check appropriate box for federal tax classification of the person whose name is entered on line 1. Check only one of the following seven boxes.		4 Exemptions (codes apply only to certain entities, not individuals; see instructions on page 3): Exempt payee code (if any) _____ Exemption from FATCA reporting code (if any) _____ <i>(Applies to accounts maintained outside the U.S.)</i>
	<input type="checkbox"/> Individual/sole proprietor or single-member LLC <input type="checkbox"/> C Corporation <input type="checkbox"/> S Corporation <input type="checkbox"/> Partnership <input type="checkbox"/> Trust/estate			
	<input type="checkbox"/> Limited liability company. Enter the tax classification (C=C corporation, S=S corporation, P=Partnership) ▶ _____ Note: Check the appropriate box in the line above for the tax classification of the single-member owner. Do not check LLC if the LLC is classified as a single-member LLC that is disregarded from the owner unless the owner of the LLC is another LLC that is not disregarded from the owner for U.S. federal tax purposes. Otherwise, a single-member LLC that is disregarded from the owner should check the appropriate box for the tax classification of its owner.			
	5	Address (number, street, and apt. or suite no.) See instructions.		Requester's name and address (optional)
	6	City, state, and ZIP code		
7	List account number(s) here (optional)			

Part I Taxpayer Identification Number (TIN)

Enter your TIN in the appropriate box. The TIN provided must match the name given on line 1 to avoid backup withholding. For individuals, this is generally your social security number (SSN). However, for a resident alien, sole proprietor, or disregarded entity, see the instructions for Part I, later. For other entities, it is your employer identification number (EIN). If you do not have a number, see *How to get a TIN*, later.

Note: If the account is in more than one name, see the instructions for line 1. Also see *What Name and Number To Give the Requester* for guidelines on whose number to enter.

Social security number									
-					-				
or									
Employer identification number									
-					-				

Part II Certification

Under penalties of perjury, I certify that:

1. The number shown on this form is my correct taxpayer identification number (or I am waiting for a number to be issued to me); and
2. I am not subject to backup withholding because: (a) I am exempt from backup withholding, or (b) I have not been notified by the Internal Revenue Service (IRS) that I am subject to backup withholding as a result of a failure to report all interest or dividends, or (c) the IRS has notified me that I am no longer subject to backup withholding; and
3. I am a U.S. citizen or other U.S. person (defined below); and
4. The FATCA code(s) entered on this form (if any) indicating that I am exempt from FATCA reporting is correct.

Certification instructions. You must cross out item 2 above if you have been notified by the IRS that you are currently subject to backup withholding because you have failed to report all interest and dividends on your tax return. For real estate transactions, item 2 does not apply. For mortgage interest paid, acquisition or abandonment of secured property, cancellation of debt, contributions to an individual retirement arrangement (IRA), and generally, payments other than interest and dividends, you are not required to sign the certification, but you must provide your correct TIN. See the instructions for Part II, later.

Sign Here	Signature of U.S. person ▶	Date ▶
------------------	----------------------------	--------

General Instructions

Section references are to the Internal Revenue Code unless otherwise noted.

Future developments. For the latest information about developments related to Form W-9 and its instructions, such as legislation enacted after they were published, go to www.irs.gov/FormW9.

Purpose of Form

An individual or entity (Form W-9 requester) who is required to file an information return with the IRS must obtain your correct taxpayer identification number (TIN) which may be your social security number (SSN), individual taxpayer identification number (ITIN), adoption taxpayer identification number (ATIN), or employer identification number (EIN), to report on an information return the amount paid to you, or other amount reportable on an information return. Examples of information returns include, but are not limited to, the following.

- Form 1099-INT (interest earned or paid)

- Form 1099-DIV (dividends, including those from stocks or mutual funds)
- Form 1099-MISC (various types of income, prizes, awards, or gross proceeds)
- Form 1099-B (stock or mutual fund sales and certain other transactions by brokers)
- Form 1099-S (proceeds from real estate transactions)
- Form 1099-K (merchant card and third party network transactions)
- Form 1098 (home mortgage interest), 1098-E (student loan interest), 1098-T (tuition)
- Form 1099-C (canceled debt)
- Form 1099-A (acquisition or abandonment of secured property)

Use Form W-9 only if you are a U.S. person (including a resident alien), to provide your correct TIN.

If you do not return Form W-9 to the requester with a TIN, you might be subject to backup withholding. See What is backup withholding, later.

By signing the filled-out form, you:

1. Certify that the TIN you are giving is correct (or you are waiting for a number to be issued),
2. Certify that you are not subject to backup withholding, or
3. Claim exemption from backup withholding if you are a U.S. exempt payee. If applicable, you are also certifying that as a U.S. person, your allocable share of any partnership income from a U.S. trade or business is not subject to the withholding tax on foreign partners' share of effectively connected income, and
4. Certify that FATCA code(s) entered on this form (if any) indicating that you are exempt from the FATCA reporting, is correct. See *What is FATCA reporting*, later, for further information.

Note: If you are a U.S. person and a requester gives you a form other than Form W-9 to request your TIN, you must use the requester's form if it is substantially similar to this Form W-9.

Definition of a U.S. person. For federal tax purposes, you are considered a U.S. person if you are:

- An individual who is a U.S. citizen or U.S. resident alien;
- A partnership, corporation, company, or association created or organized in the United States or under the laws of the United States;
- An estate (other than a foreign estate); or
- A domestic trust (as defined in Regulations section 301.7701-7).

Special rules for partnerships. Partnerships that conduct a trade or business in the United States are generally required to pay a withholding tax under section 1446 on any foreign partners' share of effectively connected taxable income from such business. Further, in certain cases where a Form W-9 has not been received, the rules under section 1446 require a partnership to presume that a partner is a foreign person, and pay the section 1446 withholding tax. Therefore, if you are a U.S. person that is a partner in a partnership conducting a trade or business in the United States, provide Form W-9 to the partnership to establish your U.S. status and avoid section 1446 withholding on your share of partnership income.

In the cases below, the following person must give Form W-9 to the partnership for purposes of establishing its U.S. status and avoiding withholding on its allocable share of net income from the partnership conducting a trade or business in the United States.

- In the case of a disregarded entity with a U.S. owner, the U.S. owner of the disregarded entity and not the entity;
- In the case of a grantor trust with a U.S. grantor or other U.S. owner, generally, the U.S. grantor or other U.S. owner of the grantor trust and not the trust; and
- In the case of a U.S. trust (other than a grantor trust), the U.S. trust (other than a grantor trust) and not the beneficiaries of the trust.

Foreign person. If you are a foreign person or the U.S. branch of a foreign bank that has elected to be treated as a U.S. person, do not use Form W-9. Instead, use the appropriate Form W-8 or Form 8233 (see Pub. 515, *Withholding of Tax on Nonresident Aliens and Foreign Entities*).

Nonresident alien who becomes a resident alien. Generally, only a nonresident alien individual may use the terms of a tax treaty to reduce or eliminate U.S. tax on certain types of income. However, most tax treaties contain a provision known as a "saving clause." Exceptions specified in the saving clause may permit an exemption from tax to continue for certain types of income even after the payee has otherwise become a U.S. resident alien for tax purposes.

If you are a U.S. resident alien who is relying on an exception contained in the saving clause of a tax treaty to claim an exemption from U.S. tax on certain types of income, you must attach a statement to Form W-9 that specifies the following five items.

1. The treaty country. Generally, this must be the same treaty under which you claimed exemption from tax as a nonresident alien.
2. The treaty article addressing the income.
3. The article number (or location) in the tax treaty that contains the saving clause and its exceptions.
4. The type and amount of income that qualifies for the exemption from tax.
5. Sufficient facts to justify the exemption from tax under the terms of the treaty article.

Example. Article 20 of the U.S.-China income tax treaty allows an exemption from tax for scholarship income received by a Chinese student temporarily present in the United States. Under U.S. law, this student will become a resident alien for tax purposes if his or her stay in the United States exceeds 5 calendar years. However, paragraph 2 of the first Protocol to the U.S.-China treaty (dated April 30, 1984) allows the provisions of Article 20 to continue to apply even after the Chinese student becomes a resident alien of the United States. A Chinese student who qualifies for this exception (under paragraph 2 of the first protocol) and is relying on this exception to claim an exemption from tax on his or her scholarship or fellowship income would attach to Form W-9 a statement that includes the information described above to support that exemption.

If you are a nonresident alien or a foreign entity, give the requester the appropriate completed Form W-8 or Form 8233.

Backup Withholding

What is backup withholding? Persons making certain payments to you must under certain conditions withhold and pay to the IRS 24% of such payments. This is called "backup withholding." Payments that may be subject to backup withholding include interest, tax-exempt interest, dividends, broker and barter exchange transactions, rents, royalties, nonemployee pay, payments made in settlement of payment card and third party network transactions, and certain payments from fishing boat operators. Real estate transactions are not subject to backup withholding.

You will not be subject to backup withholding on payments you receive if you give the requester your correct TIN, make the proper certifications, and report all your taxable interest and dividends on your tax return.

Payments you receive will be subject to backup withholding if:

1. You do not furnish your TIN to the requester,
2. You do not certify your TIN when required (see the instructions for Part II for details),
3. The IRS tells the requester that you furnished an incorrect TIN,
4. The IRS tells you that you are subject to backup withholding because you did not report all your interest and dividends on your tax return (for reportable interest and dividends only), or
5. You do not certify to the requester that you are not subject to backup withholding under 4 above (for reportable interest and dividend accounts opened after 1983 only).

Certain payees and payments are exempt from backup withholding. See *Exempt payee code*, later, and the separate Instructions for the Requester of Form W-9 for more information.

Also see *Special rules for partnerships*, earlier.

What is FATCA Reporting?

The Foreign Account Tax Compliance Act (FATCA) requires a participating foreign financial institution to report all United States account holders that are specified United States persons. Certain payees are exempt from FATCA reporting. See *Exemption from FATCA reporting code*, later, and the Instructions for the Requester of Form W-9 for more information.

Updating Your Information

You must provide updated information to any person to whom you claimed to be an exempt payee if you are no longer an exempt payee and anticipate receiving reportable payments in the future from this person. For example, you may need to provide updated information if you are a C corporation that elects to be an S corporation, or if you no longer are tax exempt. In addition, you must furnish a new Form W-9 if the name or TIN changes for the account; for example, if the grantor of a grantor trust dies.

Penalties

Failure to furnish TIN. If you fail to furnish your correct TIN to a requester, you are subject to a penalty of \$50 for each such failure unless your failure is due to reasonable cause and not to willful neglect.

Civil penalty for false information with respect to withholding. If you make a false statement with no reasonable basis that results in no backup withholding, you are subject to a \$500 penalty.

Criminal penalty for falsifying information. Willfully falsifying certifications or affirmations may subject you to criminal penalties including fines and/or imprisonment.

Misuse of TINs. If the requester discloses or uses TINs in violation of federal law, the requester may be subject to civil and criminal penalties.

Specific Instructions

Line 1

You must enter one of the following on this line; **do not** leave this line blank. The name should match the name on your tax return.

If this Form W-9 is for a joint account (other than an account maintained by a foreign financial institution (FFI)), list first, and then circle, the name of the person or entity whose number you entered in Part I of Form W-9. If you are providing Form W-9 to an FFI to document a joint account, each holder of the account that is a U.S. person must provide a Form W-9.

a. **Individual.** Generally, enter the name shown on your tax return. If you have changed your last name without informing the Social Security Administration (SSA) of the name change, enter your first name, the last name as shown on your social security card, and your new last name.

Note: ITIN applicant: Enter your individual name as it was entered on your Form W-7 application, line 1a. This should also be the same as the name you entered on the Form 1040/1040A/1040EZ you filed with your application.

b. **Sole proprietor or single-member LLC.** Enter your individual name as shown on your 1040/1040A/1040EZ on line 1. You may enter your business, trade, or “doing business as” (DBA) name on line 2.

c. **Partnership, LLC that is not a single-member LLC, C corporation, or S corporation.** Enter the entity’s name as shown on the entity’s tax return on line 1 and any business, trade, or DBA name on line 2.

d. **Other entities.** Enter your name as shown on required U.S. federal tax documents on line 1. This name should match the name shown on the charter or other legal document creating the entity. You may enter any business, trade, or DBA name on line 2.

e. **Disregarded entity.** For U.S. federal tax purposes, an entity that is disregarded as an entity separate from its owner is treated as a “disregarded entity.” See Regulations section 301.7701-2(c)(2)(iii). Enter the owner’s name on line 1. The name of the entity entered on line 1 should never be a disregarded entity. The name on line 1 should be the name shown on the income tax return on which the income should be reported. For example, if a foreign LLC that is treated as a disregarded entity for U.S. federal tax purposes has a single owner that is a U.S. person, the U.S. owner’s name is required to be provided on line 1. If the direct owner of the entity is also a disregarded entity, enter the first owner that is not disregarded for federal tax purposes. Enter the disregarded entity’s name on line 2, “Business name/disregarded entity name.” If the owner of the disregarded entity is a foreign person, the owner must complete an appropriate Form W-8 instead of a Form W-9. This is the case even if the foreign person has a U.S. TIN.

Line 2

If you have a business name, trade name, DBA name, or disregarded entity name, you may enter it on line 2.

Line 3

Check the appropriate box on line 3 for the U.S. federal tax classification of the person whose name is entered on line 1. Check only one box on line 3.

IF the entity/person on line 1 is a(n) . . .	THEN check the box for . . .
• Corporation	Corporation
• Individual • Sole proprietorship, or • Single-member limited liability company (LLC) owned by an individual and disregarded for U.S. federal tax purposes.	Individual/sole proprietor or single-member LLC
• LLC treated as a partnership for U.S. federal tax purposes, • LLC that has filed Form 8832 or 2553 to be taxed as a corporation, or • LLC that is disregarded as an entity separate from its owner but the owner is another LLC that is not disregarded for U.S. federal tax purposes.	Limited liability company and enter the appropriate tax classification. (P= Partnership; C= C corporation; or S= S corporation)
• Partnership	Partnership
• Trust/estate	Trust/estate

Line 4, Exemptions

If you are exempt from backup withholding and/or FATCA reporting, enter in the appropriate space on line 4 any code(s) that may apply to you.

Exempt payee code.

- Generally, individuals (including sole proprietors) are not exempt from backup withholding.
- Except as provided below, corporations are exempt from backup withholding for certain payments, including interest and dividends.
- Corporations are not exempt from backup withholding for payments made in settlement of payment card or third party network transactions.
- Corporations are not exempt from backup withholding with respect to attorneys’ fees or gross proceeds paid to attorneys, and corporations that provide medical or health care services are not exempt with respect to payments reportable on Form 1099-MISC.

The following codes identify payees that are exempt from backup withholding. Enter the appropriate code in the space in line 4.

- 1—An organization exempt from tax under section 501(a), any IRA, or a custodial account under section 403(b)(7) if the account satisfies the requirements of section 401(f)(2)
- 2—The United States or any of its agencies or instrumentalities
- 3—A state, the District of Columbia, a U.S. commonwealth or possession, or any of their political subdivisions or instrumentalities
- 4—A foreign government or any of its political subdivisions, agencies, or instrumentalities
- 5—A corporation
- 6—A dealer in securities or commodities required to register in the United States, the District of Columbia, or a U.S. commonwealth or possession
- 7—A futures commission merchant registered with the Commodity Futures Trading Commission
- 8—A real estate investment trust
- 9—An entity registered at all times during the tax year under the Investment Company Act of 1940
- 10—A common trust fund operated by a bank under section 584(a)
- 11—A financial institution
- 12—A middleman known in the investment community as a nominee or custodian
- 13—A trust exempt from tax under section 664 or described in section 4947

The following chart shows types of payments that may be exempt from backup withholding. The chart applies to the exempt payees listed above, 1 through 13.

IF the payment is for . . .	THEN the payment is exempt for . . .
Interest and dividend payments	All exempt payees except for 7
Broker transactions	Exempt payees 1 through 4 and 6 through 11 and all C corporations. S corporations must not enter an exempt payee code because they are exempt only for sales of noncovered securities acquired prior to 2012.
Barter exchange transactions and patronage dividends	Exempt payees 1 through 4
Payments over \$600 required to be reported and direct sales over \$5,000 ¹	Generally, exempt payees 1 through 5 ²
Payments made in settlement of payment card or third party network transactions	Exempt payees 1 through 4

¹ See Form 1099-MISC, Miscellaneous Income, and its instructions.

² However, the following payments made to a corporation and reportable on Form 1099-MISC are not exempt from backup withholding: medical and health care payments, attorneys' fees, gross proceeds paid to an attorney reportable under section 6045(f), and payments for services paid by a federal executive agency.

Exemption from FATCA reporting code. The following codes identify payees that are exempt from reporting under FATCA. These codes apply to persons submitting this form for accounts maintained outside of the United States by certain foreign financial institutions. Therefore, if you are only submitting this form for an account you hold in the United States, you may leave this field blank. Consult with the person requesting this form if you are uncertain if the financial institution is subject to these requirements. A requester may indicate that a code is not required by providing you with a Form W-9 with "Not Applicable" (or any similar indication) written or printed on the line for a FATCA exemption code.

A—An organization exempt from tax under section 501(a) or any individual retirement plan as defined in section 7701(a)(37)

B—The United States or any of its agencies or instrumentalities

C—A state, the District of Columbia, a U.S. commonwealth or possession, or any of their political subdivisions or instrumentalities

D—A corporation the stock of which is regularly traded on one or more established securities markets, as described in Regulations section 1.1472-1(c)(1)(i)

E—A corporation that is a member of the same expanded affiliated group as a corporation described in Regulations section 1.1472-1(c)(1)(i)

F—A dealer in securities, commodities, or derivative financial instruments (including notional principal contracts, futures, forwards, and options) that is registered as such under the laws of the United States or any state

G—A real estate investment trust

H—A regulated investment company as defined in section 851 or an entity registered at all times during the tax year under the Investment Company Act of 1940

I—A common trust fund as defined in section 584(a)

J—A bank as defined in section 581

K—A broker

L—A trust exempt from tax under section 664 or described in section 4947(a)(1)

M—A tax exempt trust under a section 403(b) plan or section 457(g) plan

Note: You may wish to consult with the financial institution requesting this form to determine whether the FATCA code and/or exempt payee code should be completed.

Line 5

Enter your address (number, street, and apartment or suite number). This is where the requester of this Form W-9 will mail your information returns. If this address differs from the one the requester already has on file, write NEW at the top. If a new address is provided, there is still a chance the old address will be used until the payor changes your address in their records.

Line 6

Enter your city, state, and ZIP code.

Part I. Taxpayer Identification Number (TIN)

Enter your TIN in the appropriate box. If you are a resident alien and you do not have and are not eligible to get an SSN, your TIN is your IRS individual taxpayer identification number (ITIN). Enter it in the social security number box. If you do not have an ITIN, see *How to get a TIN* below.

If you are a sole proprietor and you have an EIN, you may enter either your SSN or EIN.

If you are a single-member LLC that is disregarded as an entity separate from its owner, enter the owner's SSN (or EIN, if the owner has one). Do not enter the disregarded entity's EIN. If the LLC is classified as a corporation or partnership, enter the entity's EIN.

Note: See *What Name and Number To Give the Requester*, later, for further clarification of name and TIN combinations.

How to get a TIN. If you do not have a TIN, apply for one immediately. To apply for an SSN, get Form SS-5, Application for a Social Security Card, from your local SSA office or get this form online at www.SSA.gov. You may also get this form by calling 1-800-772-1213. Use Form W-7, Application for IRS Individual Taxpayer Identification Number, to apply for an ITIN, or Form SS-4, Application for Employer Identification Number, to apply for an EIN. You can apply for an EIN online by accessing the IRS website at www.irs.gov/Businesses and clicking on Employer Identification Number (EIN) under Starting a Business. Go to www.irs.gov/Forms to view, download, or print Form W-7 and/or Form SS-4. Or, you can go to www.irs.gov/OrderForms to place an order and have Form W-7 and/or SS-4 mailed to you within 10 business days.

If you are asked to complete Form W-9 but do not have a TIN, apply for a TIN and write "Applied For" in the space for the TIN, sign and date the form, and give it to the requester. For interest and dividend payments, and certain payments made with respect to readily tradable instruments, generally you will have 60 days to get a TIN and give it to the requester before you are subject to backup withholding on payments. The 60-day rule does not apply to other types of payments. You will be subject to backup withholding on all such payments until you provide your TIN to the requester.

Note: Entering "Applied For" means that you have already applied for a TIN or that you intend to apply for one soon.

Caution: A disregarded U.S. entity that has a foreign owner must use the appropriate Form W-8.

Part II. Certification

To establish to the withholding agent that you are a U.S. person, or resident alien, sign Form W-9. You may be requested to sign by the withholding agent even if item 1, 4, or 5 below indicates otherwise.

For a joint account, only the person whose TIN is shown in Part I should sign (when required). In the case of a disregarded entity, the person identified on line 1 must sign. Exempt payees, see *Exempt payee code*, earlier.

Signature requirements. Complete the certification as indicated in items 1 through 5 below.

1. Interest, dividend, and barter exchange accounts opened before 1984 and broker accounts considered active during 1983.

You must give your correct TIN, but you do not have to sign the certification.

2. Interest, dividend, broker, and barter exchange accounts opened after 1983 and broker accounts considered inactive during 1983.

You must sign the certification or backup withholding will apply. If you are subject to backup withholding and you are merely providing your correct TIN to the requester, you must cross out item 2 in the certification before signing the form.

3. Real estate transactions.

You must sign the certification. You may cross out item 2 of the certification.

4. Other payments. You must give your correct TIN, but you do not have to sign the certification unless you have been notified that you have previously given an incorrect TIN. "Other payments" include payments made in the course of the requester's trade or business for rents, royalties, goods (other than bills for merchandise), medical and health care services (including payments to corporations), payments to a nonemployee for services, payments made in settlement of payment card and third party network transactions, payments to certain fishing boat crew members and fishermen, and gross proceeds paid to attorneys (including payments to corporations).

5. Mortgage interest paid by you, acquisition or abandonment of secured property, cancellation of debt, qualified tuition program payments (under section 529), ABLE accounts (under section 529A), IRA, Coverdell ESA, Archer MSA or HSA contributions or distributions, and pension distributions. You must give your correct TIN, but you do not have to sign the certification.

What Name and Number To Give the Requester

For this type of account:	Give name and SSN of:
1. Individual	The individual
2. Two or more individuals (joint account) other than an account maintained by an FFI	The actual owner of the account or, if combined funds, the first individual on the account ¹
3. Two or more U.S. persons (joint account maintained by an FFI)	Each holder of the account
4. Custodial account of a minor (Uniform Gift to Minors Act)	The minor ²
5. a. The usual revocable savings trust (grantor is also trustee)	The grantor-trustee ¹
b. So-called trust account that is not a legal or valid trust under state law	The actual owner ¹
6. Sole proprietorship or disregarded entity owned by an individual	The owner ³
7. Grantor trust filing under Optional Form 1099 Filing Method 1 (see Regulations section 1.671-4(b)(2)(i)(A))	The grantor*
For this type of account:	Give name and EIN of:
8. Disregarded entity not owned by an individual	The owner
9. A valid trust, estate, or pension trust	Legal entity ⁴
10. Corporation or LLC electing corporate status on Form 8832 or Form 2553	The corporation
11. Association, club, religious, charitable, educational, or other tax-exempt organization	The organization
12. Partnership or multi-member LLC	The partnership
13. A broker or registered nominee	The broker or nominee

For this type of account:	Give name and EIN of:
14. Account with the Department of Agriculture in the name of a public entity (such as a state or local government, school district, or prison) that receives agricultural program payments	The public entity
15. Grantor trust filing under the Form 1041 Filing Method or the Optional Form 1099 Filing Method 2 (see Regulations section 1.671-4(b)(2)(i)(B))	The trust

¹ List first and circle the name of the person whose number you furnish. If only one person on a joint account has an SSN, that person's number must be furnished.

² Circle the minor's name and furnish the minor's SSN.

³ You must show your individual name and you may also enter your business or DBA name on the "Business name/disregarded entity" name line. You may use either your SSN or EIN (if you have one), but the IRS encourages you to use your SSN.

⁴ List first and circle the name of the trust, estate, or pension trust. (Do not furnish the TIN of the personal representative or trustee unless the legal entity itself is not designated in the account title.) Also see *Special rules for partnerships*, earlier.

*Note: The grantor also must provide a Form W-9 to trustee of trust.

Note: If no name is circled when more than one name is listed, the number will be considered to be that of the first name listed.

Secure Your Tax Records From Identity Theft

Identity theft occurs when someone uses your personal information such as your name, SSN, or other identifying information, without your permission, to commit fraud or other crimes. An identity thief may use your SSN to get a job or may file a tax return using your SSN to receive a refund.

To reduce your risk:

- Protect your SSN,
- Ensure your employer is protecting your SSN, and
- Be careful when choosing a tax preparer.

If your tax records are affected by identity theft and you receive a notice from the IRS, respond right away to the name and phone number printed on the IRS notice or letter.

If your tax records are not currently affected by identity theft but you think you are at risk due to a lost or stolen purse or wallet, questionable credit card activity or credit report, contact the IRS Identity Theft Hotline at 1-800-908-4490 or submit Form 14039.

For more information, see Pub. 5027, Identity Theft Information for Taxpayers.

Victims of identity theft who are experiencing economic harm or a systemic problem, or are seeking help in resolving tax problems that have not been resolved through normal channels, may be eligible for Taxpayer Advocate Service (TAS) assistance. You can reach TAS by calling the TAS toll-free case intake line at 1-877-777-4778 or TTY/TDD 1-800-829-4059.

Protect yourself from suspicious emails or phishing schemes.

Phishing is the creation and use of email and websites designed to mimic legitimate business emails and websites. The most common act is sending an email to a user falsely claiming to be an established legitimate enterprise in an attempt to scam the user into surrendering private information that will be used for identity theft.

The IRS does not initiate contacts with taxpayers via emails. Also, the IRS does not request personal detailed information through email or ask taxpayers for the PIN numbers, passwords, or similar secret access information for their credit card, bank, or other financial accounts.

If you receive an unsolicited email claiming to be from the IRS, forward this message to phishing@irs.gov. You may also report misuse of the IRS name, logo, or other IRS property to the Treasury Inspector General for Tax Administration (TIGTA) at 1-800-366-4484. You can forward suspicious emails to the Federal Trade Commission at spam@uce.gov or report them at www.ftc.gov/complaint. You can contact the FTC at www.ftc.gov/idtheft or 877-IDTHEFT (877-438-4338). If you have been the victim of identity theft, see www.IdentityTheft.gov and Pub. 5027.

Visit www.irs.gov/IdentityTheft to learn more about identity theft and how to reduce your risk.

Privacy Act Notice

Section 6109 of the Internal Revenue Code requires you to provide your correct TIN to persons (including federal agencies) who are required to file information returns with the IRS to report interest, dividends, or certain other income paid to you; mortgage interest you paid; the acquisition or abandonment of secured property; the cancellation of debt; or contributions you made to an IRA, Archer MSA, or HSA. The person collecting this form uses the information on the form to file information returns with the IRS, reporting the above information. Routine uses of this information include giving it to the Department of Justice for civil and criminal litigation and to cities, states, the District of Columbia, and U.S. commonwealths and possessions for use in administering their laws. The information also may be disclosed to other countries under a treaty, to federal and state agencies to enforce civil and criminal laws, or to federal law enforcement and intelligence agencies to combat terrorism. You must provide your TIN whether or not you are required to file a tax return. Under section 3406, payers must generally withhold a percentage of taxable interest, dividend, and certain other payments to a payee who does not give a TIN to the payer. Certain penalties may also apply for providing false or fraudulent information.

PROOF OF INSURANCE

This is to certify that the following endorsement is part of the policy(ies) described below:

NAMED INSURED (CONTRACTOR)

COMPANIES AFFORDING COVERAGE

ADDRESS

A.
B.
C.

It is hereby understood and agreed that the city of Owosso, its city council and each member thereof and every officer and employee of the city shall be named as joint and several assureds with respect to claims arising out of the following project:

2021 Street Program – Contract 1

It is further agreed that the following indemnity agreement between the city of Owosso and the named insured is covered under this policy: Contractor agrees to indemnify, hold harmless and defend city, its city council and each member thereof and every officer and employee of city from any and all liability or financial loss resulting from any suits, claims, losses or actions brought against and from all costs and expenses of litigation brought against city, its city council and each member thereof and any officer or employee of city which results directly or indirectly from the wrongful or negligent actions of contractor’s officers, employees, agents or others employed by Contractor while engaged by contractor in the (performance of this agreement) construction of this project.

It is further agreed that the inclusion of more than one assured shall not operate to increase the limit of the company’s liability and that insurer waives any right on contribution with insurance which may be available to the city of Owosso.

The contractor, or any of their subcontractors, shall not commence work under this contract until they have attained the insurance required below, and shall keep such insurance in force during the entire life of this contract. All coverage shall be with insurance companies licensed and admitted to do business in the State of Michigan and acceptable to the city of Owosso. The requirements below should not be interpreted to limit the liability of the Contractor. All deductibles and SIR’s are the responsibility of the Contractor.

The Contractor shall procure and maintain the following insurance coverage:

1. **Worker’s Compensation Insurance** including Employers’ Liability Coverage, in accordance with all applicable statutes of the State of Michigan.
2. **Commercial General Liability Insurance** on an “Occurrence Basis” with limits of liability not less than \$1,000,000 per occurrence and aggregate. Coverage shall include the following extensions: (A) Contractual Liability; (B) Products and Completed Operations; (C) Independent Contractors Coverage; (D) Broad Form General Liability Extensions or equivalent, if not already included.
3. **Automobile Liability** including Michigan No-Fault Coverages, with limits of liability not less than \$1,000,000 per occurrence, combined single limit for Bodily Injury, and Property Damage. Coverage shall include all owned vehicles, all non-owned vehicles, and all hired vehicles.
4. **Additional Insured:** Commercial General Liability and Automobile Liability, as described above, shall include an endorsement stating the following shall be **Additional Insureds:** City of Owosso, all elected and appointed officials, all employees and volunteers, all boards, commissions, and/or authorities and board members, including employees and volunteers thereof. It is understood and agreed by naming City of Owosso as additional insured, coverage afforded is considered to be primary and any other insurance the city of Owosso may have in effect shall be considered secondary and/or excess.
5. **Cancellation Notice:** All policies, as described above, shall include an endorsement stating that it is understood and agreed that a Ten (10) days notice for non-payment of premium is required and a Thirty (30) days notice is required for Non-Renewal, Reduction, and/or Material Change, shall be sent to: City of Owosso, Bid Coordinator, 301 W. Main Street, Owosso, Michigan 48867.

6. **Proof of Insurance Coverage:** The Contractor shall provide the city of Owosso, at the time that the contracts are returned by him/her for execution, a Certificate of Insurance as well as the required endorsements. In lieu of required endorsements, if applicable, a copy of the policy sections where coverage is provided for additional insured and cancellation notice would be acceptable. Copies or certified copies of all policies mentioned above shall be furnished, if so requested.

If any of the above coverages expire during the term of this contract, the Contractor shall deliver renewal certificates and endorsements to the city of Owosso at least ten (10) days prior to the expiration date.

Please include a copy of insurance declaration verifying amounts of coverage. The verification of insurance is not an insurance policy and does not amend, extend or alter the coverage afforded by the policies listed herein. Notwithstanding any requirement, term, or condition of any contract or other document with respect to which this certificate or verification of insurance may be issued or may pertain, the insurance afforded by the policies described herein is subject to all the terms, exclusions and conditions of such policies.

DATE _____

BY _____
Authorized Insurance Agent

AGENCY _____

TITLE _____

ADDRESS _____

PROGRESS CLAUSE

City of Owosso/CW

1 of 1

May, 2021

In no case shall any work be commenced prior to receipt of formal notice of award by the City of Owosso.

The Contractor shall prepare and submit a complete, detailed, and signed MDOT Form 1130, Progress Schedule, according to 12SP-101A.

The progress schedule shall include, at minimum, the controlling work items for the completion of the project, as well as the planned dates or work days that these work items will be controlling operations. All contract dates including open to traffic, project completion, interim completion, and any other controlling dates in the contract, must be included in the Progress Schedule.

If the bidding Proposal specifies controlling dates, these shall also be included in the Progress Schedule.

The contractor is required to coordinate work with the following criteria:

1. No work shall begin before August 16, 2021.
2. All work shall be completed on or before October 29, 2021.

After award and prior to the start of work, the Contractor must attend a preconstruction meeting with the Engineer. The Engineer will determine the day, time, and place for the preconstruction meeting. The meeting will be conducted after project award and may be rescheduled if there are delays in the award of the project. The named subcontractor(s) for Designated and/or Specialty items, as shown in the proposal should attend the preconstruction meeting if such items materially affect the work schedule.

Liquidated Damages shall be assessed in accordance with Section 108.10 of the 2012 Standard Specifications for Construction.

**SPECIAL PROVISION
FOR
TECHNICAL SPECIFICATIONS**

RC/City of Owosso

1 OF 1

Dec, 2018

General Requirement

The MDOT 2012 STANDARD SPECIFICATIONS FOR CONSTRUCTION shall govern all technical specifications for this project. The following parts of the Contract will prevail over all other parts in the following order:

1. Special Provisions.
2. Supplemental Specifications.
3. Project Plans and Drawings.
4. MDOT Standard Plans.
5. 2012 Standard Specifications
6. City of Owosso Standard Specifications.

The Contractor shall not take advantage of any apparent error or omission in the contract documents. If any uncertainty, inconsistency, omission, or conflict is discovered within the contract documents, the Engineer will solely decide as to the true intent of the language.

NOTICE TO BIDDERS

UTILITY COORDINATION

City of Owosso/CW

1 of 2

May, 2021

The Contractor shall cooperate and coordinate construction activities with the owners of utilities as stated in Section 104.08 of the Michigan Department of Transportation 2012 Standard Specifications for Construction. In addition, for the protection of underground utilities, the contractor shall follow the requirements in Section 107.12 of the Michigan Department of Transportation 2012 Standard Specifications for Construction. Contractor delay claims, resulting from a utility, will be determined based upon Section 108.09 of the Michigan Department of Transportation 2012 Standard Specifications for Construction.

The following Public Utilities have facilities located in the road right-of-way or project area:

UTILITY	OWNER	CONTACT
Cable Television	Charter Communication 1480 S. Valley Center Dr Bay City, Michigan 48706	Mark Kelly (989) 233-9404 mark.kelly@charter.com
Fiber Optic	Frontier 1943 W. M-21 Owosso, Michigan 48867	Mark Stevens (989) 723-0373 mark.stevens@ftr.com
Gas	Consumers Energy 530 West Willow Street PO Box 30162 Lansing, Michigan 48909	Adam Bertram (517) 614-8570 adam.bertram@cmsenergy.com
Electric	Consumers Energy 530 West Willow Street PO Box 30162 Lansing, Michigan 48906	Tracy Mahar (989) 729-3250 tracy.mahar@cmsenergy.com
Water Sanitary Sewer	City of Owosso 301 W. Main Street Owosso, MI 48867	Ryan Suchanek (989) 725-0555 ryan.suchanek@ci.owosso.mi.us
Road Storm Sewer	City of Owosso 301 W. Main Street Owosso, MI 48867	Clayton Wehner, PE (989) 725-0551 clayton.wehner@ci.owosso.mi.us
Fiber Optic	DayStarr Communications 307 N. Ball Street Owosso, MI 48867	Brent Klein (989) 720-6023 brent.klein@daystarrfiber.net
Soil Erosion Control	Shiawassee County Health Department Environmental Health Division 201 N. Shiawassee Street Corunna, Michigan 48817	Steve Alworden (989) 743-2289 salworden@shiawaseechd.net

For protection of underground utilities and in conformance with Public Act 53, the Contractor shall dial 1-800-482-7171 (or 811) a minimum of three full working days, excluding Saturdays, Sundays, and holidays prior to beginning each excavation in areas where public utilities have not been previously located. Members will thus be routinely notified. This does not relieve the Contractor of the responsibility of notifying utility owners who may not be a part of the "Miss Dig" alert system.

The existing utilities shown on the plans represent the best information available as obtained from survey and existing records. This information does not relieve the Contractor of the responsibility of protecting all existing utilities, in case utilities have been constructed or removed since the survey date or if utilities are encountered in different locations or if any utilities are not shown on the plans.

All existing utilities shall be located as to both horizontal and vertical position prior to starting any utility construction or other excavation. Cost shall be included in the new utility or excavation pay item.

The Contractor's attention is directed to the requirements for cooperation with others, as covered in Section 104.08 of the MDOT 2012 Standard Specification for Construction.

UTILITY DAMAGE

The Contractor shall be responsible for the protection of all existing utilities during construction of this project. Any utilities damaged by the Contractor shall be repaired in accordance with the related utilities specifications at the Contractor's expense.

UTILITY REPLACEMENTS

There are no utility replacements for the project.

CITY OF OWOSSO
SPECIAL PROVISION
FOR
MAINTAINING TRAFFIC

City of Owosso/CW

1 of 4

May, 2021

a. Description. The project will consist of 0.75 miles of road crushing, shaping, base stabilizing, and HMA resurfacing, including curb and gutter, sidewalk, storm sewer on six city streets: Garfield Avenue, Glenwood Avenue, Lincoln Avenue, McMillan Avenue, Park Street, and Pearce Street in the City of Owosso, Shiawassee County.

b. General. Traffic shall be maintained in accordance with Sections 104.07C, 104.11. 812, and 922 of the Michigan Department of Transportation (MDOT) 2012 Standard Specifications for Construction, including any typicals or supplemental specifications and as specified herein.

The Contractor shall coordinate their operations with other Contractors, City of Owosso forces, and private utilities within the CIA to eliminate conflicts in traffic control. No additional payment will be made to the Contractor for the joint use of traffic control items.

The Contractor shall notify the Engineer, City of Owosso (989-725-0550), Shiawassee County Central Dispatch (989-743-9111), and Local Fire Department(s) (989-725-0580) that service the area a minimum of three full working days prior to the implementation of any detours or road closures.

c. Construction Influence Area (CIA). The Construction Influence Area shall include the right-of-ways of the six streets under construction and extend a distance of 0.5 miles beyond the endpoints and include the right-of-way of all intersecting streets within the project limits a distance of 500 feet laterally from the construction centerlines of the six streets under construction.

The CIA shall also include the rights-of-way of any designed detour routes within the limits of the construction and detour signing.

d. Traffic Restrictions. The roads shall be closed to through traffic. Residents shall be allowed to access their driveways at all times, except when construction requires short term closures. When one lane in each direction cannot be maintained, at least one lane of traffic shall be maintained by using traffic regulators during day light hours and one lane of traffic in each direction shall be available at night.

The Contractor shall use the City of Owosso Truck Route System. In scenarios where the project site cannot be reached using only the City of Owosso Truck Route System, the shortest possible route shall be used to reach the project site.

Reasonable access to intersecting roads/streets and residential/commercial drives shall be maintained at all times. The Contractor may temporarily close alternate drives if a business or residence has multiple drives on the same roadway, except for drives that operate directionally (i.e. one way drives).

Should traffic regulators be assigned to maintain local traffic through the construction area, the cost for traffic regulators will not be paid for separately but will be considered part of the pay item Minor Traffic Devices. All traffic regulators assigned to traffic control must receive all necessary instruction and training prior to starting operations.

The Contractor shall work between the hours of 7:00 a.m. and 7:00 p.m., Monday through Saturday. No work is allowed outside these time periods. The Contractor must provide 24-hour notice for Saturday work. The Contractor shall coordinate work so that any necessary preliminary or closing operations are also done within these time periods.

No work shall be allowed during the Fourth of July or Labor Day holiday periods. The Fourth of July holiday period shall begin on Friday, July 2, 2021 at 3:00 p.m. and continue through Tuesday, July 6, 2021 at the normal starting time. The Labor Day holiday period shall begin on Friday, September 3, 2021 at 3:00 p.m. and continue through Tuesday, September 7, 2021 at the normal starting time.

The Contractor shall place maintenance gravel the same workday that the pavement is removed in all locations of the project to maintain access to adjacent properties. Any damage occurring to the subgrade from exposure to the elements will be undercut and replaced in accordance with Subgrade Undercutting, Type II, at the Contractor's expense.

The Contractor shall place aggregate base the same workday that the earth is excavated in all locations of the project. Any damage occurring to the subgrade from exposure to the elements will be undercut and replaced in accordance with Subgrade Undercutting, Type II, at the Contractor's expense.

Rubbish collection is done by private contractors between the hours of 7:00 a.m. and 7:00 p.m. according to the following schedule: All residential customers north of Main Street are serviced on Thursdays. All residential customers south of Main Street are serviced on Tuesdays. Rubbish collected at commercial properties is collected any time/date. The Contractor shall schedule work to allow and provide for rubbish collectors to provide their service to residential and commercial properties. If the rubbish collectors are unable to collect materials due to construction operations, then the Contractor shall coordinate with the rubbish collectors the moving of containers to the collection site and returning same containers to the property owners.

Current mail delivery is both via mailbox and doorstep. The Mail delivery person will park their vehicle on a side street and walk to residence to make doorstep delivery. The Contractor shall conduct work so that the mail person may drive and walk unimpeded around construction work to make their delivery.

e. Traffic Control Devices. All signs, barricades, warning lights, and other traffic control devices shall be in accordance with the 2011 Edition of the Michigan Manual on Uniform Traffic Control Devices (MMUTCD) and conform to MDOT Special Detail WZD-125-E.

All diamond shaped warning signs shall be 48" x 48". All temporary signs shall be mounted at a minimum seven-foot bottom height. All temporary signs used for detour, except those at Type III Barricades, shall be installed on driven posts.

Temporary signs that are to remain in place for fourteen (14) days or more shall be installed on driven posts as directed by the Engineer. All other temporary signs (excluding detour signs) may be installed on portable supports.

Ground driven sign supports for temporary signs shall be installed in accordance with MDOT Special Detail WZD-100-A.

Advance work zone signing is revised to include R5-18c (Work Zone Begins) signs. Install signs at locations shown in the plans or as directed by the Engineer.

For construction signing, layout as shown on MDOT typicals minimum Merging Taper Length "L", distances between Traffic Control Devices "D", and length of Longitudinal Buffer Length "B" shall be in accordance with Typical Sign Sequence M0020a.

During paving operations, traffic regulators (flaggers) shall be utilized, and intermediate traffic regulators (flaggers) shall be established at intersecting roads, streets, and at other traffic generators as directed by the Engineer.

W20-1 "Road Work Ahead" signs shall be placed on all intersecting roads at a minimum distance shown on the plans, or as directed by the Engineer.

Signs placed at Type III barricades shall be placed above and behind the barricade on their own supports.

A quantity of plastic drums with fluorescent sheeting has been established for lane closures and to be used adjacent to work areas.

g. Measurement and Payment. The Maintaining Traffic Pay Items will be paid for at the Contract Unit Price in accordance with MDOT 2012 Standard Specifications for Construction, with the exception by other Special Provisions, which shall be payment in full for all labor, material, and equipment needed to accomplish this work.

Payment for temporary signs will be made based on the maximum square feet of dissimilar sign legends in use at any one time during the project.

Payment for barricades, lighted arrows, and plastic drums will be made based on the maximum number in use at any one time during the project.

CITY OF
OWOSSO
 SHIawassee COUNTY
 T. 7 N.-R. 2 & 3 E.
 POP. 17,179 - 1970 CENSUS

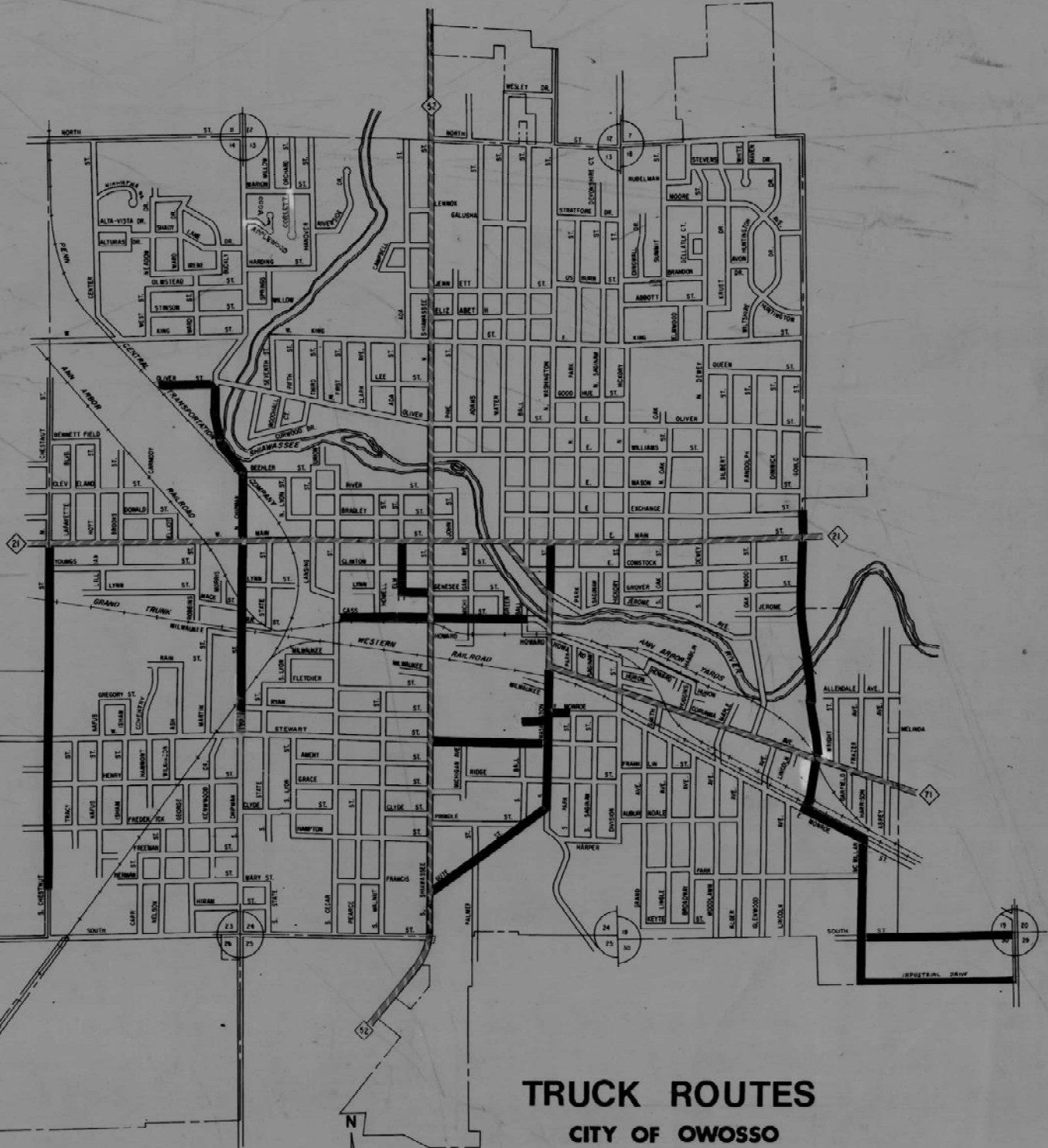

TRUCK ROUTES
CITY OF OWOSSO

TRAFFIC CONTROL ORDER
 EFFECTIVE DATE 6-15-81

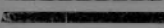
STATE HIGHWAY 
 DESIGNATED TRUCK ROUTES 

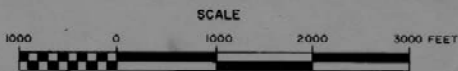

SIGN MATERIAL SELECTION TABLE

SIGN SIZE	SIGN MATERIAL TYPE		
	TYPE I	TYPE II	TYPE III
≤ 36" X 36"		X	X
>36" X 36" < 96" TO WIDE		X	
> 96" WIDE TO 144" WIDE	X	X	
> 144" WIDE	X		

TYPE I ALUMINUM EXTRUSION
 TYPE II PLYWOOD
 TYPE III ALUMINUM SHEET

ROUNDING OF CORNERS IS NOT REQUIRED FOR TYPE I OR II SIGNS.
 VERTICAL JOINTS ARE NOT PERMITTED.
 HORIZONTAL JOINTS THROUGH SIGN LEGEND OR SYMBOLS ARE NOT PERMITTED.

POST SIZE REQUIREMENTS TABLE

SIGN AREA (ft ²)	POST TYPE		
	U-CHANNEL STEEL	SQUARE TUBULAR STEEL	WOOD
≤9	1 - 3 lb/ft*	1 - 2" 12 or 14 GA*	N/A
9 ≤ 20	2 - 3 lb/ft	2 - 2" 12 or 14 GA	1 - 4" X 6"*
> 20 ≤ 30	N/A	N/A	2 - 4" X 6"
> 30 ≤ 60	N/A	N/A	2 - 6" X 8"
> 60 ≤ 84	N/A	N/A	3 - 6" X 8"

*SIGNS 4 FEET AND GREATER IN WIDTH REQUIRE 2 POSTS.
 SIGNS GREATER THAN 8 FEET IN WIDTH REQUIRE 2 OR 3 WOOD
 POSTS DEPENDING ON AREA OF SIGN.
 A MAXIMUM OF 2 POSTS WITHIN A 7' PATH IS PERMITTED.

 PREPARED BY OPERATIONS FIELD SERVICES	DEPARTMENT DIRECTOR Kirk T. Steudle APPROVED BY: _____ DIRECTOR, BUREAU OF FIELD SERVICES	MICHIGAN DEPARTMENT OF TRANSPORTATION BUREAU OF FIELD SERVICES SPECIAL DETAIL FOR GROUND DRIVEN SIGN SUPPORTS FOR TEMP SIGNS		
	DRAWN BY: <u>CON/ECH</u> CHECKED BY: <u>AUG</u>	APPROVED BY: _____ DIRECTOR, BUREAU OF HIGHWAY DEVELOPMENT	_____ F.H.W.A. APPROVAL	<u>7/20/2016</u> PLAN DATE

2 POST SIGN SUPPORT SPACING

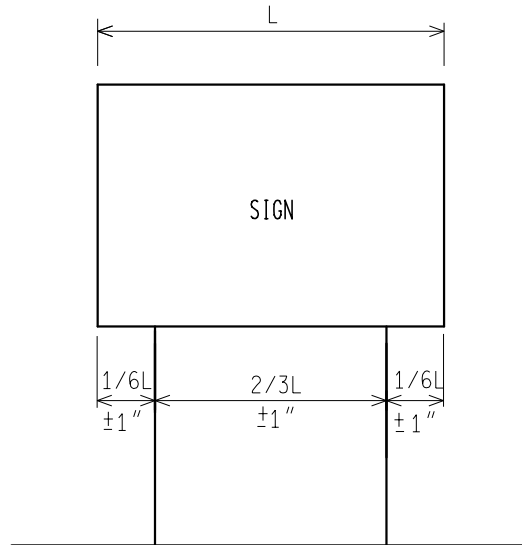

3 POST SIGN SUPPORT SPACING

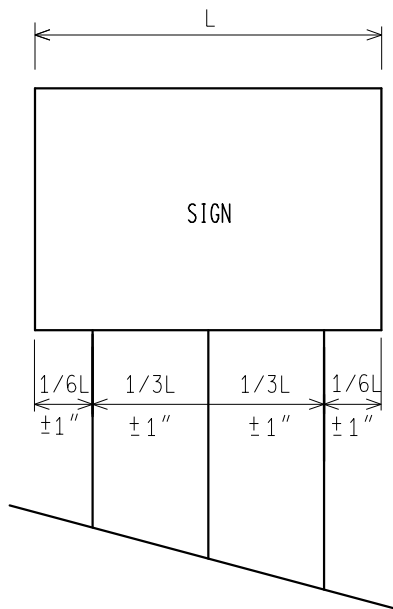

* FOR ALL 11' AND 12' LONG SIGNS ON 3 WOOD SUPPORTS, SPREAD POSTS SO AS TO HAVE A 8' MIN. TO 9' MAX. DISTANCE BETWEEN OUTSIDE POSTS.

NOT TO SCALE

MICHIGAN DEPARTMENT OF TRANSPORTATION
BUREAU OF FIELD SERVICES SPECIAL DETAIL

F.H.W.A. APPROVAL

7/20/2016
PLAN DATE

WZD-100-A

SHEET
2 OF 11

NOTE: THE ORIGINAL SIGNED COPY IS KEPT ON FILE AT THE MICHIGAN DEPARTMENT OF TRANSPORTATION.

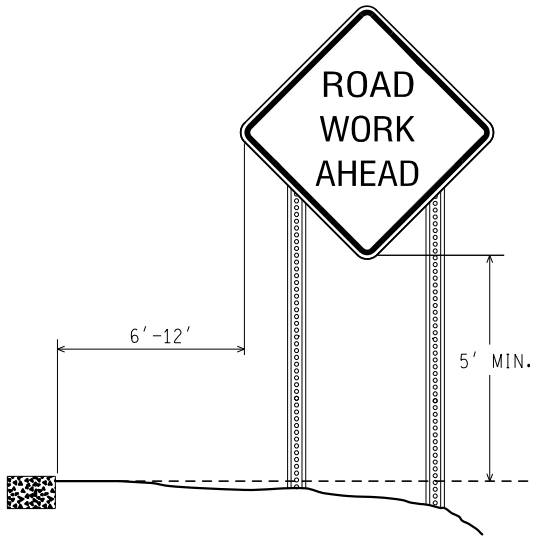

RURAL

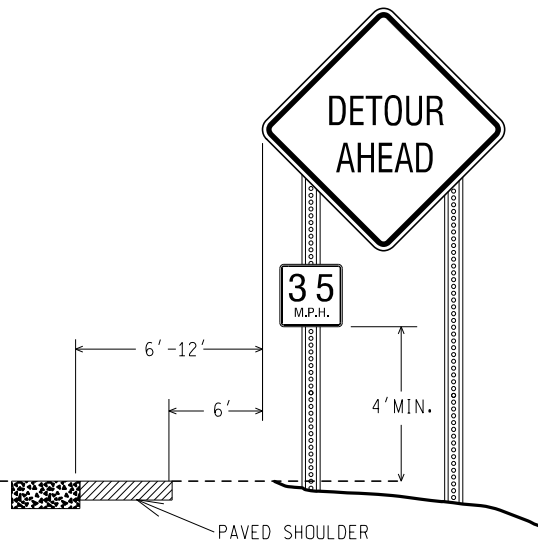

RURAL WITH ADVISORY SPEED PLATE

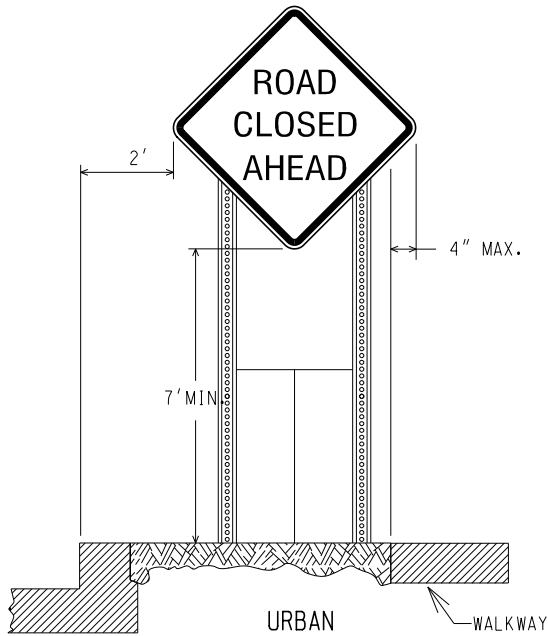

(CURBED AREAS OR WHERE WALKWAYS ARE PRESENT)

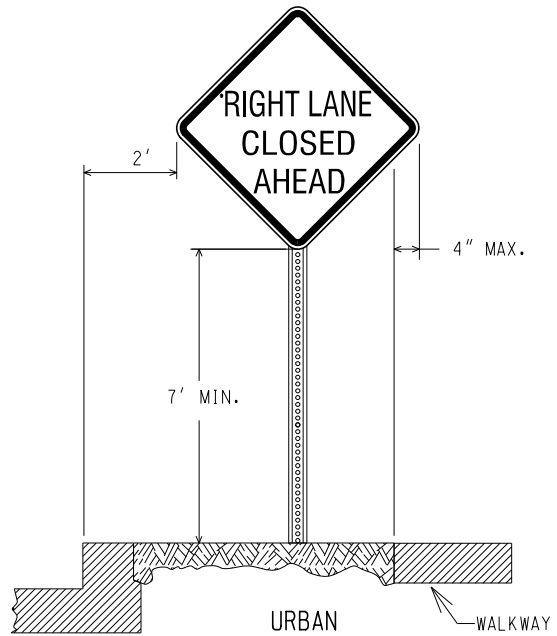

(CURBED AREAS OR WHERE WALKWAYS ARE PRESENT)

BOTTOM HEIGHT AND OFFSET

NOT TO SCALE

MICHIGAN DEPARTMENT OF TRANSPORTATION
BUREAU OF FIELD SERVICES SPECIAL DETAIL

F.H.W.A. APPROVAL

7/20/2016
PLAN DATE

WZD-100-A

SHEET
3 OF 11

NOTE: THE ORIGINAL SIGNED COPY IS KEPT ON FILE AT THE MICHIGAN DEPARTMENT OF TRANSPORTATION.

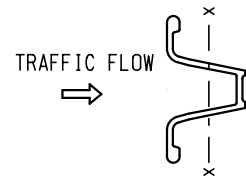
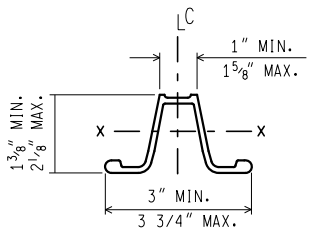
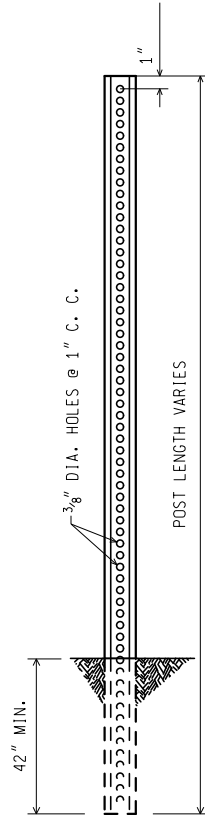

WEIGHT = 3 lbs/ft
 SECT. MOD. X.-X. = 0.31 CUBIC INCHES MIN.

3 lb. U - CHANNEL STEEL POST
 (NO SPLICE)

MOUNT SIGN ON OPEN FACE OF
 U - CHANNEL STEEL POST

NOT TO SCALE

MICHIGAN DEPARTMENT OF TRANSPORTATION BUREAU OF FIELD SERVICES SPECIAL DETAIL	F.H.W.A. APPROVAL	7/20/2016 PLAN DATE	WZD-100-A	SHEET 4 OF 11
--	-------------------	------------------------	-----------	------------------

NOTE: THE ORIGINAL SIGNED COPY IS KEPT ON FILE AT THE MICHIGAN DEPARTMENT OF TRANSPORTATION.

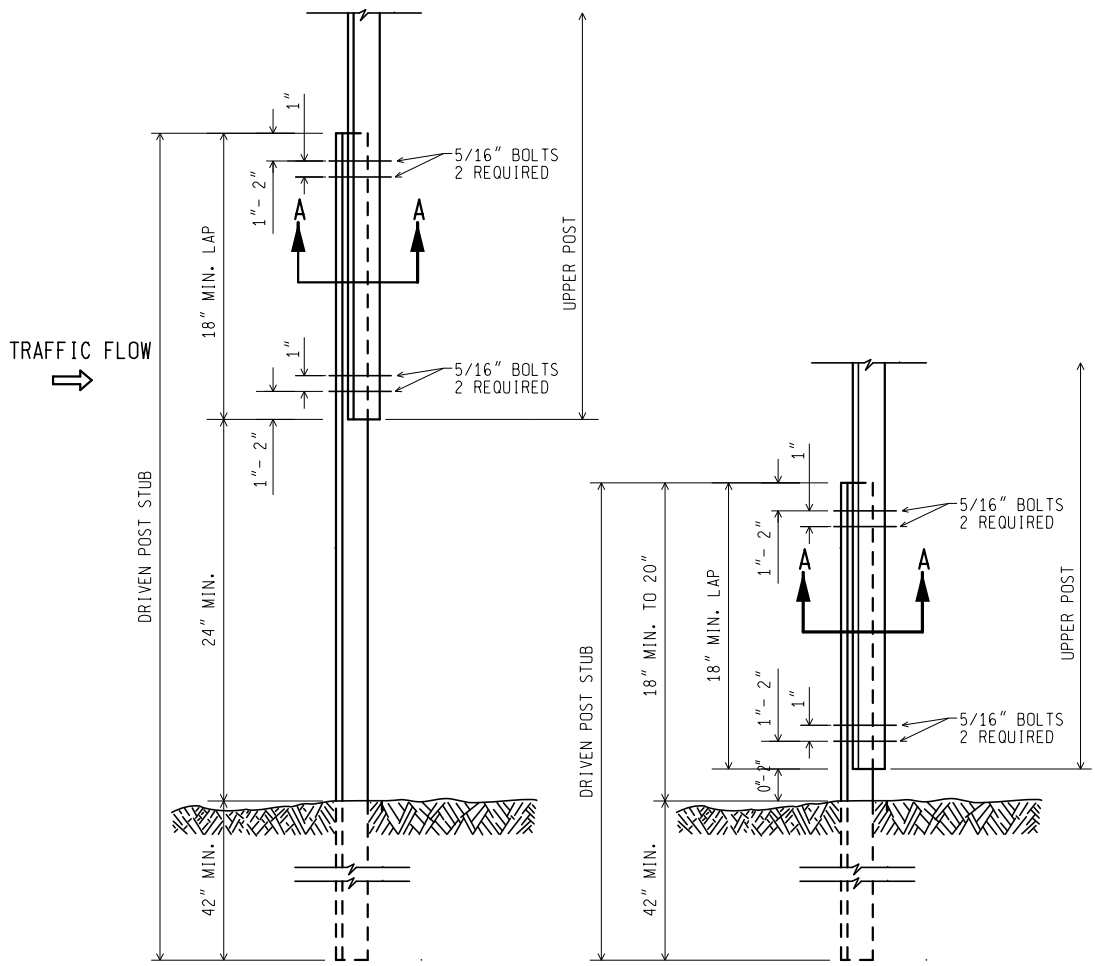

3 lb. U - CHANNEL STEEL POST
(WITH SPLICE)

MOUNT SIGN ON OPEN FACE OF
UPPER U - CHANNEL STEEL POST

NOT TO SCALE

MICHIGAN DEPARTMENT OF TRANSPORTATION BUREAU OF FIELD SERVICES SPECIAL DETAIL	F.H.W.A. APPROVAL	7/20/2016 PLAN DATE	WZD-100-A	SHEET 5 OF 11
--	-------------------	------------------------	-----------	------------------

NOTE: THE ORIGINAL SIGNED COPY IS KEPT ON FILE AT THE MICHIGAN DEPARTMENT OF TRANSPORTATION.

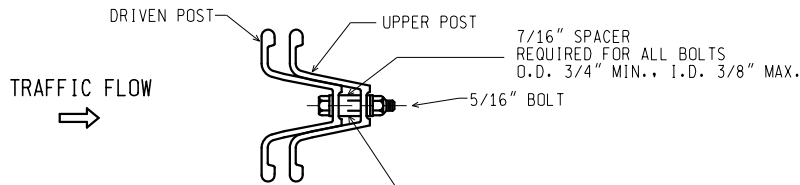

SECTION A-A

7/16" SPACER
 REQUIRED FOR ALL BOLTS
 O.D. 3/4" MIN., I.D. 3/8" MAX.

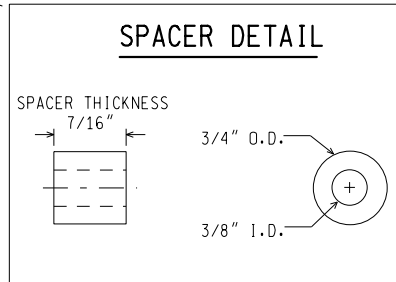

NOTES:

1. THE SPACER THICKNESS SHALL BE 1/16" LESS THAN THE GAP BETWEEN THE POST WHEN POSITIONED IN THE UNBOLTED CONFIGURATION.
2. THE EXTERIOR BOLT (CLOSEST TO LAP), SPACER, WASHER, AND NUT SHALL BE INSTALLED IN A PREPUNCHED HOLE 1" TO 2" FROM THE END OF THE LAP.
3. THE INTERIOR BOLT (FARTHEST FROM LAP), SPACER, WASHER, AND NUT SHALL BE INSTALLED IN THE NEXT PREPUNCHED HOLE.
4. THE DRIVEN POST SHALL ALWAYS BE MOUNTED IN FRONT OF THE UPPER POST WITH RESPECT TO THE ADJACENT ONCOMING TRAFFIC, REGARDLESS OF THE DIRECTION THE SIGN IS FACING.
5. THE SPLICE LAP SHALL BE FASTENED BY FOUR-5/16" DIA. GALVANIZED A449 BOLTS (SAE J429 GRADE 5) OR GALVANIZED A325 BOLTS.

3 lb. U - CHANNEL STEEL POST
 (WITH SPLICE)

NOT TO SCALE

MICHIGAN DEPARTMENT OF TRANSPORTATION BUREAU OF FIELD SERVICES SPECIAL DETAIL	F.H.W.A. APPROVAL	7/20/2016 PLAN DATE	WZD-100-A	SHEET 6 OF 11
--	-------------------	------------------------	-----------	------------------

NOTE: THE ORIGINAL SIGNED COPY IS KEPT ON FILE AT THE MICHIGAN DEPARTMENT OF TRANSPORTATION.

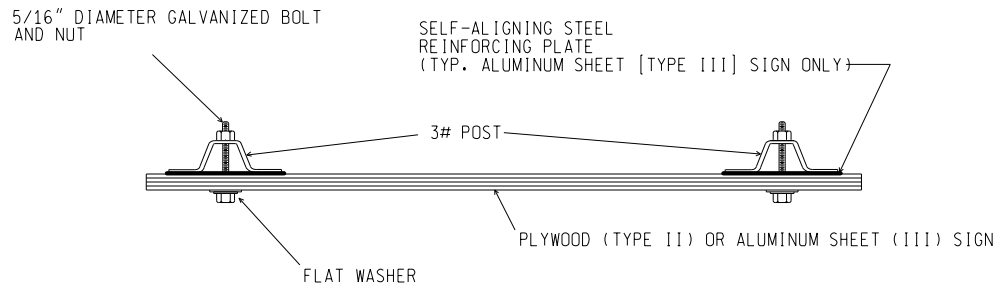

SIGN TO 3 lb. POST CONNECTION

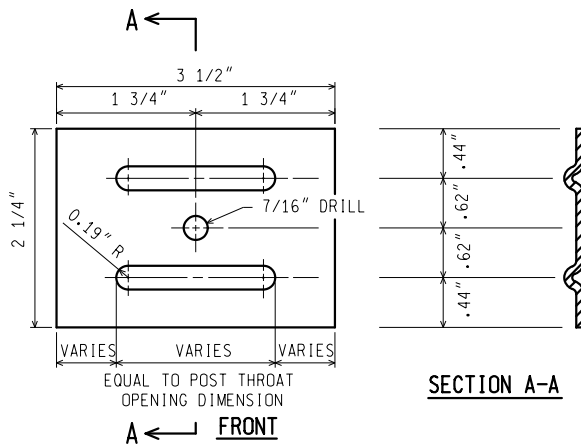

NOTES: (FOR STEEL SIGN REINF' PLATE)

1. MATERIAL: 12 GAUGE CARBON STEEL.
2. TOLERANCE ON ALL DIMENSIONS $\pm 0.0625"$
3. FINISH-AFTER STAMPING AND PUNCHING, GALVANIZE ACCORDING TO CURRENT SPECIFICATIONS FOR ZINC (HOT GALVANIZE) COATINGS ON PRODUCTS FABRICATED FROM PLATES OR STRIPS

STEEL SIGN REINFORCING PLATE
REQUIRED FOR TYPE III SIGNS ONLY

3 lb. U - CHANNEL STEEL POST SIGN CONNECTION

NOT TO SCALE

MICHIGAN DEPARTMENT OF TRANSPORTATION
BUREAU OF FIELD SERVICES SPECIAL DETAIL

F.H.W.A. APPROVAL

7/20/2016
PLAN DATE

WZD-100-A

SHEET
7 OF 11

NOTE: THE ORIGINAL SIGNED COPY IS KEPT ON FILE AT THE MICHIGAN DEPARTMENT OF TRANSPORTATION.

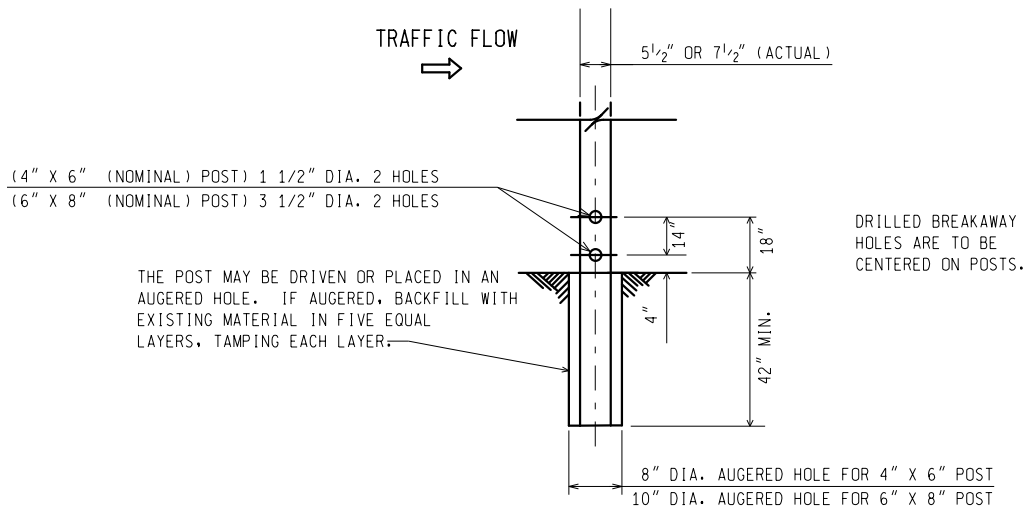

WOOD POST BREAKAWAY HOLES/
 DIRECT EMBEDMENT DETAILS

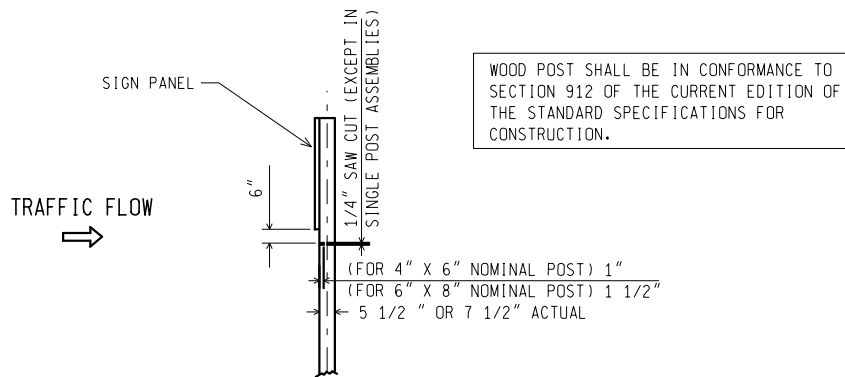

SAW CUT DETAIL
 (MULTIPLE POST INSTALLATIONS)

WOOD POST DETAILS

NOT TO SCALE

MICHIGAN DEPARTMENT OF TRANSPORTATION BUREAU OF FIELD SERVICES SPECIAL DETAIL	F.H.W.A. APPROVAL	7/20/2016 PLAN DATE	WZD-100-A	SHEET 8 OF 11
--	-------------------	------------------------	-----------	------------------

NOTE: THE ORIGINAL SIGNED COPY IS KEPT ON FILE AT THE MICHIGAN DEPARTMENT OF TRANSPORTATION.

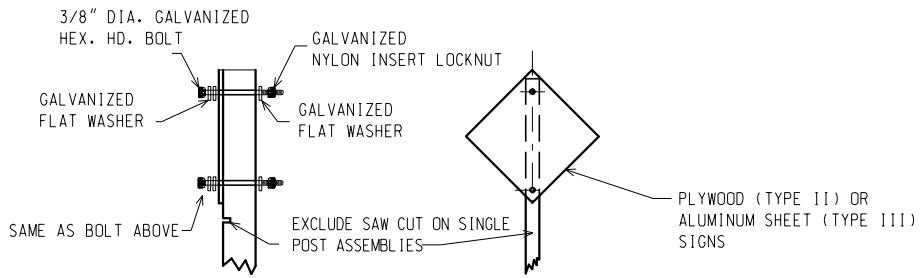

TYPE II AND TYPE III SIGNS

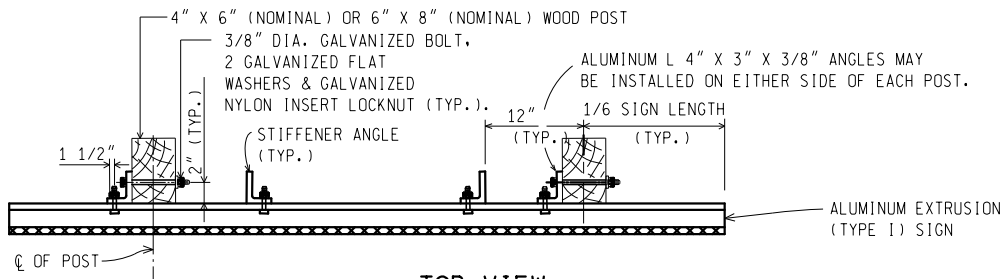

**TOP VIEW
TYPE I SIGN**

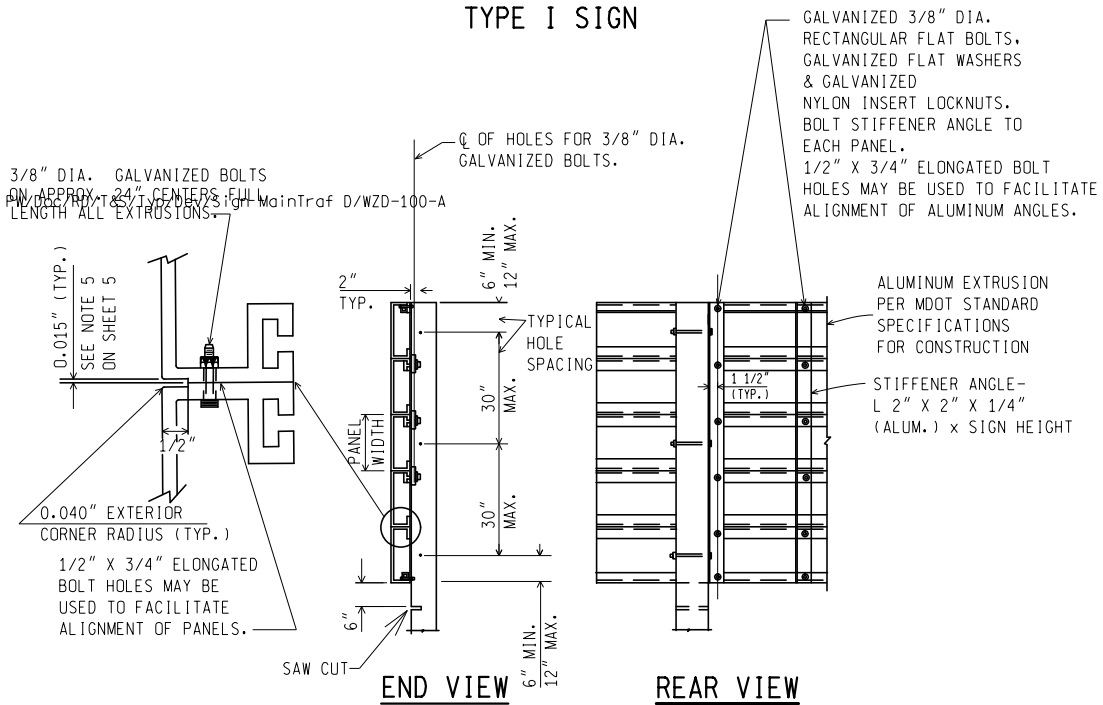

TYPE I SIGN - ERECTION DETAILS

WOOD POST CONNECTIONS

NOT TO SCALE

MICHIGAN DEPARTMENT OF TRANSPORTATION
BUREAU OF FIELD SERVICES SPECIAL DETAIL

F.H.W.A. APPROVAL

7/20/2016
PLAN DATE

WZD-100-A

SHEET
9 OF 11

NOTE: THE ORIGINAL SIGNED COPY IS KEPT ON FILE AT THE MICHIGAN DEPARTMENT OF TRANSPORTATION.

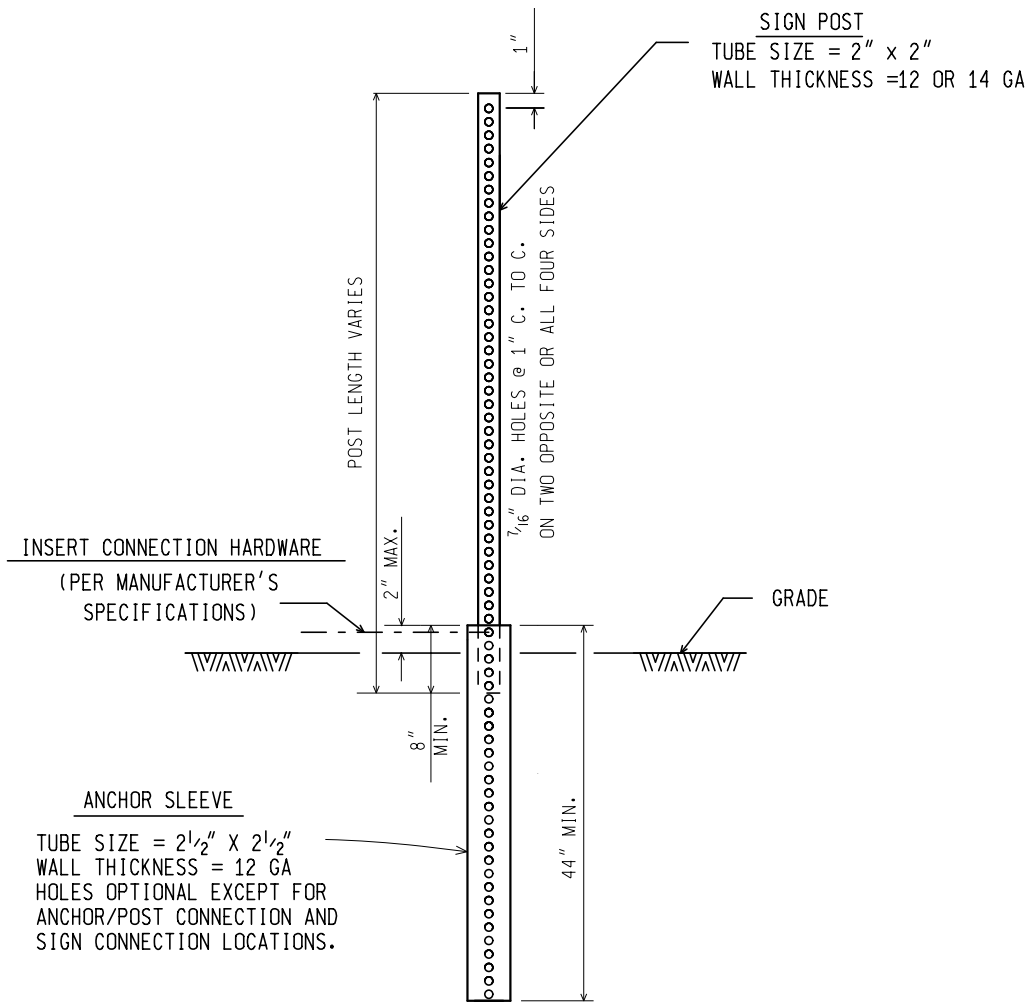

SQUARE TUBULAR STEEL POST

NOT TO SCALE

MICHIGAN DEPARTMENT OF TRANSPORTATION BUREAU OF FIELD SERVICES SPECIAL DETAIL	F.H.W.A. APPROVAL	7/20/2016 PLAN DATE	WZD-100-A	SHEET 10 OF 11
--	-------------------	------------------------	-----------	-------------------

NOTE: THE ORIGINAL SIGNED COPY IS KEPT ON FILE AT THE MICHIGAN DEPARTMENT OF TRANSPORTATION.

GENERAL NOTES:

1. A MAXIMUM OF TWO POSTS WITHIN A 7 FOOT PATH IS PERMITTED.
2. ALL SIGN POSTS SHALL COMPLY WITH NCHRP 350.
3. ALL POSTS SHALL BE EMBEDDED A MINIMUM OF 42".
4. BRACING OF POST IS NOT PERMITTED.
5. SIGN SHALL BE LEVEL, AND UPRIGHT FOR THE DURATION OF INSTALLATION.
6. ERECT POSTS SO THE SIGN FACE AND SUPPORTS DO NOT VARY FROM PLUMB BY MORE THAN 3/16" IN 3'. PROVIDE A CENTER-TO-CENTER DISTANCE BETWEEN POSTS WITHIN 2 PERCENT OF PLAN DISTANCE.
7. NO MORE THAN ONE SPLICE PER POST, AS SHOWN, WILL BE PERMITTED.
8. POST TYPES SHALL NOT BE MIXED WITHIN A SIGN SUPPORT INSTALLATION.
9. NO VERTICAL JOINTS ARE PERMITTED IN SIGN. NO HORIZONTAL JOINTS THROUGH SIGN LEGEND OR SYMBOLS ARE PERMITTED IN SIGN
10. REMOVE SIGN POSTS AND/OR POST STUBS IN THEIR ENTIRETY WHEN NO LONGER REQUIRED.
11. ALL LABOR, MATERIALS, AND EQUIPMENT, INCLUDING TEMPORARY SUPPORTS REQUIRED TO INSTALL, MAINTAIN, RELOCATE, AND/OR REMOVE THE TEMPORARY SIGN, INCLUDING SUPPORTS, ARE CONSIDERED TO BE INCLUDED IN THE COST OF THE TEMPORARY SIGN.
12. SAW CUTS IN WOOD POSTS ARE TO BE PARALLEL TO THE BOTTOM OF THE SIGN.
13. POSTS SHALL NOT EXTEND MORE THAN 4" ABOVE TOP OF SIGN.
14. TEMPORARY WOOD SUPPORTS DO NOT REQUIRE PRESERVATIVE TREATMENT.

NOT TO SCALE

MICHIGAN DEPARTMENT OF TRANSPORTATION BUREAU OF FIELD SERVICES SPECIAL DETAIL	F.H.W.A. APPROVAL	7/20/2016 PLAN DATE	WZD-100-A	SHEET 11 OF 11
--	-------------------	------------------------	-----------	-------------------

NOTE: THE ORIGINAL SIGNED COPY IS KEPT ON FILE AT THE MICHIGAN DEPARTMENT OF TRANSPORTATION.

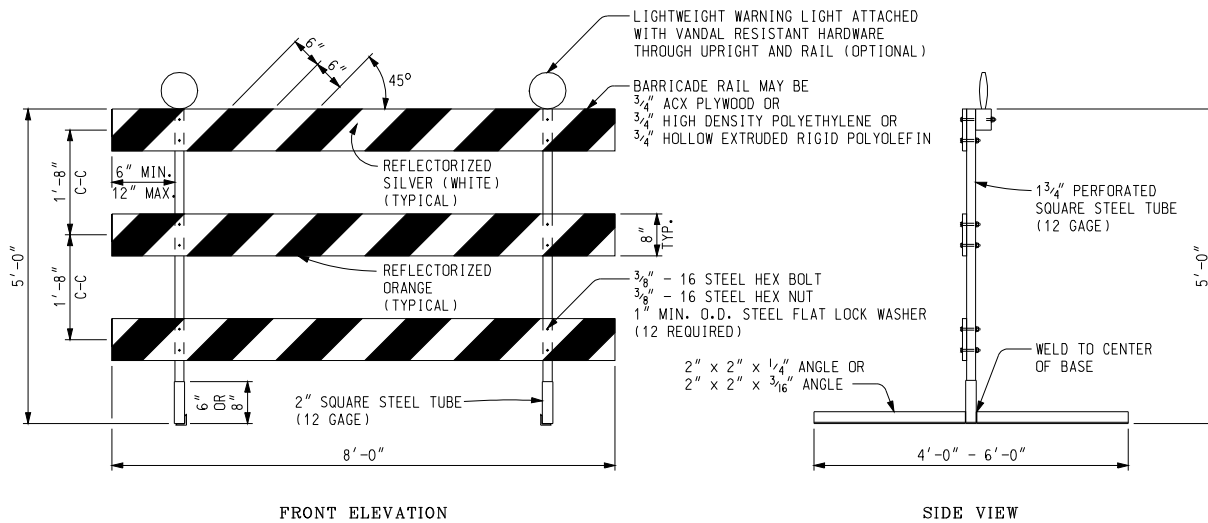

PERFORATED SQUARE STEEL TUBE OPTION

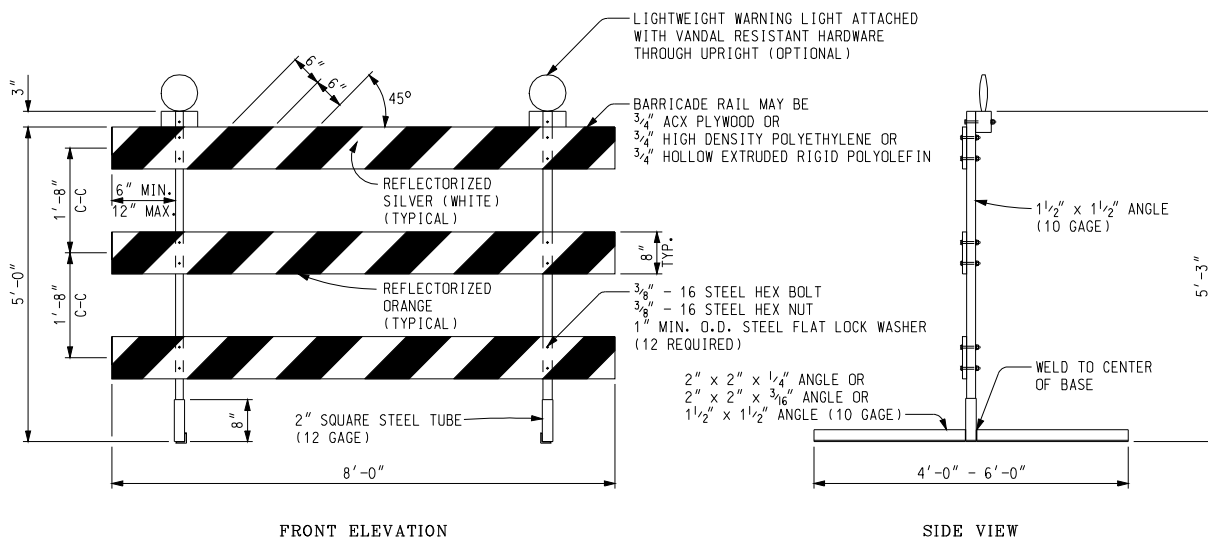

ANGLE IRON OPTION

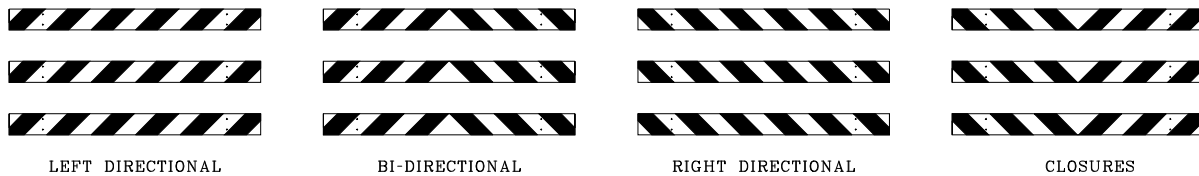

BARRICADE RAIL SHEETING OPTIONS
TYPE III BARRICADES

Other Type III Barricades meeting current NCHRP crash worthy criteria can be found on the FHWA Safety website at

http://safety.fhwa.dot.gov/roadway_dept/road_hardware/wzd.htm

NOT TO SCALE

File: T&S/Typ/Signs/WorkZones/wzd 125 d

Rev. 09/22/09 PJ



PREPARED BY
TRAFFIC AND SAFETY

DRAWN BY: ECH

CHECKED BY: MWB

ENGINEER OF DELIVERY

ENGINEER OF DEVELOPMENT

(SPECIAL DETAIL)

FHWA APPROVAL DATE

MICHIGAN DEPARTMENT OF TRANSPORTATION
BUREAU OF HIGHWAYS DELIVERY STANDARD PLAN FOR

Temporary
Traffic Control Devices

9/22/09
PLAN DATE

WZD-125-E

SHEET
1 of 3

NOTE: THE ORIGINAL SIGNED COPY IS KEPT ON FILE AT THE MICHIGAN DEPARTMENT OF TRANSPORTATION.

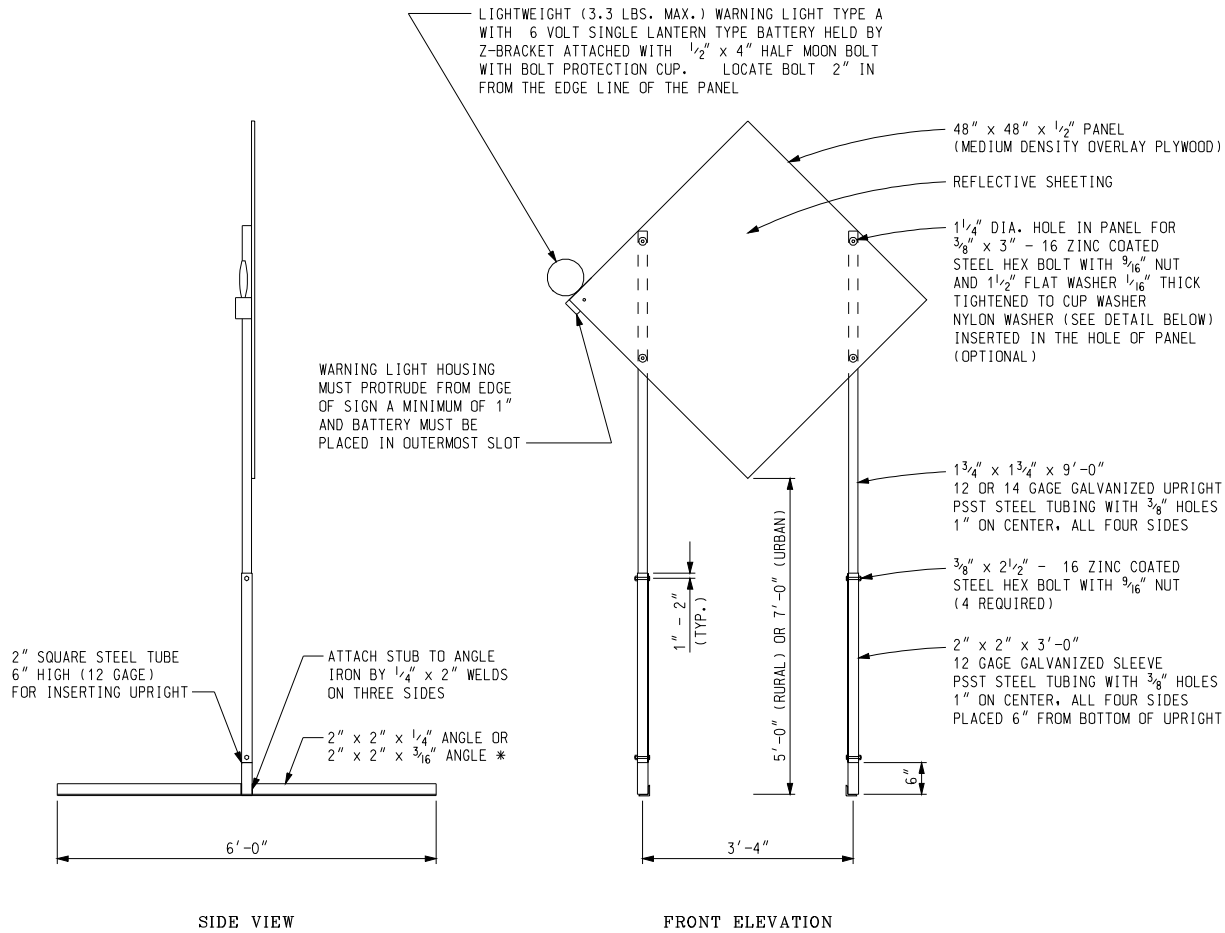

TEMPORARY SIGN SUPPORT

(WARNING LIGHT PLACED ON SIDE CLOSEST TO TRAFFIC)

* SIGN STAND IS BALLASTED WITH FOUR OR MORE 35 LB SANDBAGS. A MINIMUM OF ONE ON EACH END.
 UPRIGHTS SHALL NOT EXTEND ABOVE THE SIGN PANEL.

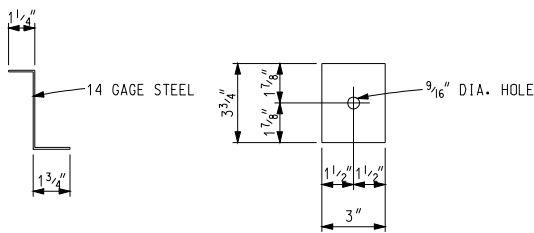

Z-BRACKET DETAIL

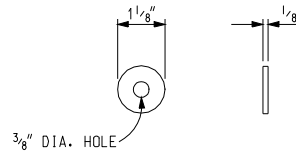

OPTIONAL NYLON WASHER

Other temporary sign supports meeting current NCHRP crash worthy criteria can be found on the FHWA Safety website at http://safety.fhwa.dot.gov/roadway_dept/road_hardware/wzd.htm

NOT TO SCALE

MICHIGAN DEPARTMENT OF TRANSPORTATION BUREAU OF HIGHWAYS DELIVERY STANDARD PLAN	(SPECIAL DETAIL) FHWA APPROVAL DATE	9/22/09	WZD-125-E	SHEET 2 of 3
File: T&S/Typ/Signs/WorkZones/wzd 125 d	Rev. 09/22/09 PJ	PLAN DATE		

NOTE: THE ORIGINAL SIGNED COPY IS KEPT ON FILE AT THE MICHIGAN DEPARTMENT OF TRANSPORTATION.

- PLASTIC DRUM
- ▲▲▲ PROPOSED TYPE III BARRICADE
- △△△ EXISTING TYPE III BARRICADE

SYMBOLS TO BE USED ON PLANS

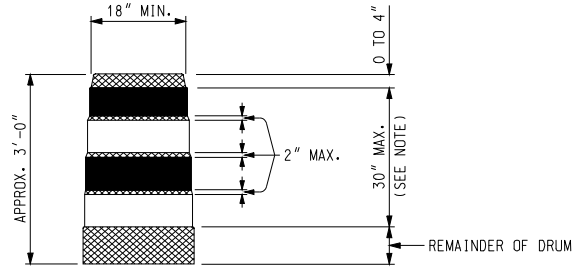

- REFLECTORIZED ORANGE
- REFLECTORIZED WHITE
- NON REFLECTORIZED ORANGE

NOTE:
 DRUMS SHALL HAVE AT LEAST 4 HORIZONTAL REFLECTORIZED STRIPES (2 ORANGE AND 2 WHITE) OF 6" UNIFORM WIDTH, ALTERNATING IN COLOR WITH THE TOPMOST REFLECTORIZED STRIPE BEING ORANGE. NON REFLECTORIZED SPACES BETWEEN THE HORIZONTAL REFLECTORIZED ORANGE AND WHITE STRIPES SHALL BE ORANGE IN COLOR AND EQUAL IN WIDTH.

PLASTIC DRUM

NOTES:

2" PERFORATED SQUARE STEEL TUBES MAY BE USED TO FABRICATE THE HORIZONTAL BASE OF THE TYPE III BARRICADE.

WARNING LIGHTS SHALL BE PLACED ACCORDING TO THE CURRENT STANDARD SPECIFICATIONS FOR CONSTRUCTION AND ALL OTHER PROVISIONS IN THE CONTRACT WHEN THEY ARE USED ON TYPE III BARRICADES.

SEE ROAD STANDARD PLANS R-113-SERIES FOR TEMPORARY CROSSOVERS FOR DIVIDED ROADWAY, AND R-126-SERIES FOR TYPICAL LOCATION AND SPACING OF PLASTIC DRUMS FOR PLACEMENT OF TEMPORARY CONCRETE BARRIER.

SIGNS, BARRICADES, AND PLASTIC DRUMS SHALL BE FACED WITH PRESSURE-SENSITIVE REFLECTIVE SHEETING ACCORDING TO THE CURRENT STANDARD SPECIFICATIONS FOR CONSTRUCTION.

SANDBAGS SHALL BE USED WHEN SUPPLEMENTAL WEIGHTS ARE REQUIRED TO ACHIEVE STABILITY OF THE BARRICADE. THE SANDBAGS SHALL BE PLACED SO THEY WILL NOT COVER OR OBSTRUCT ANY REFLECTIVE PORTION OF THE TRAFFIC CONTROL DEVICE.

NOT TO SCALE

MICHIGAN DEPARTMENT OF TRANSPORTATION BUREAU OF HIGHWAYS DELIVERY STANDARD PLAN	(SPECIAL DETAIL) FHWA APPROVAL DATE	9/22/09	WZD-125-E	SHEET 3 of 3
File: T&S/Typ/Signs/WorkZones/wzd 125 d	Rev. 09/22/09 PJ	PLAN DATE		

NOTE: THE ORIGINAL SIGNED COPY IS KEPT ON FILE AT THE MICHIGAN DEPARTMENT OF TRANSPORTATION.

CITY OF OWOSSO
SPECIAL PROVISION
FOR
ABANDONED GAS MAIN, CONFLICT

City of Owosso/CW

1 OF 1

August, 2020

The work of Abandoned Gas Main, Conflict shall be performed in accordance with Sections 402 and 702 of the MDOT 2012 Standard Specifications for Construction.

a. Description. The work of Abandoned Gas Main, Conflict consists of removing abandoned gas main, of various size and material, that directly conflicts with proposed storm sewer installation and bulk heading the two exposed ends, as shown on the plans or as directed by the Engineer. The Engineer will determine whether a conflict exists and advise the Contractor in advance of any work.

b. Materials. The materials for bulk heading shall include mortar, geotextile wrap, and tape for attachment. Mortar mix shall be Type H-1 non-shrinking mortar and grout mixture.

c. Construction. The Contractor shall expose the existing pipe crossing in advance of proposed construction and confirm with the utility that the pipe is abandoned. The Contractor shall inform the Engineer of the conflict in advance of any work. After agreement is reached, then the Contractor shall remove that portion of conflicting abandoned pipe across the trench influence area and seal each exposed remaining ends with bulk heads. The bulk heads shall be constructed such that prepared mortar mix shall be extended at least one foot into the pipe, then wrapped with geotextile material same as used for the road, and secured in place with tape.

d. Measurement and Payment. The completed as measured for Abandoned Gas Main, Conflict will be paid for at the Contract Unit Price for the following Pay Item:

Pay Item	Pay Unit
Abandoned Gas Main, Conflict.....	Each

Abandoned Gas Main, Conflict will be measured in place by the unit Each; and will be paid for at the contract unit price per Each, which price shall be payment in full for all labor, material, and equipment needed to accomplish this work.

CITY OF OWOSSO
SPECIAL PROVISION
FOR
AGGREGATE BASE, _ INCH, MODIFIED
AGGREGATE BASE, LM, MODIFIED

City of Owosso/RC

1 of 1

April, 2020

a. Description. This work shall consist of placing and compacting an aggregate base course on a prepared subbase.

b. Materials. The material shall meet the gradation requirements of the Michigan Department of Transportation (MDOT) 2012 Standard Specifications for Construction, Section 902, for 21AA aggregate, except all material shall be 100% crushed limestone.

c. Construction Methods. The material shall be placed and compacted in accordance with the MDOT 2012 Standard Specifications for Construction, Section 302.03.

d. Measurement and Payment. The completed work, Aggregate Base, _ inch, Modified including all materials, labor, and equipment, as measured will be paid for at the Contract Unit Price for the following Pay Item.

Pay Item	Pay Unit
Aggregate Base, _ inch, Modified	Square Yard
Aggregate Base, LM, Modified	Cubic Yard

Aggregate Base, _ inch, Modified will be measured in place by the square yard.

Aggregate Base, LM, Modified will be measured in place by the cubic yard.

The maximum pay width will be as shown on the plans.

**SPECIAL PROVISION
FOR
ASPHALT STABILIZED AGGREGATE BASE COURSE**

CITY OF OWOSSO/CW

1 OF 4

February, 2020

DESCRIPTION

This work will be done in accordance with the requirements of Section 305, 501, 902, and 904 of the Michigan Department of Transportation (MDOT) 2012 Standard Specifications for Construction, except as herein specified.

This work shall be accomplished in place and shall consist of blending crushed material with hot asphalt cement at the specified rate and depth, shaping to specified elevation and slope, and compacting to specified density.

MATERIALS

Materials shall meet the following requirements:

Asphalt Cement PG 52-28	904
Fog Coat SS - 1H	904
Aggregate Base 22A	902

The asphaltic material for stabilizing shall be applied at the rate and temperature (minimum 350° F) as determined by the Engineer, so that the residual bitumen added will be between two (2) and five (5) per cent by weight of the asphaltic material.

EQUIPMENT REQUIREMENTS

1. Compaction Equipment - Rollers. Rollers must meet the requirements as specified under Section 501.03 for rollers, except that combination pneumatic-steel wheel and vibratory rollers will be permitted. A minimum of three (3) rollers in operating condition will be required on the project and shall be of the following types:
 - Minimum of (2) shall be steel drum vibratory type;
 - Minimum of (1) shall be pneumatic - tire type.All rollers are to be approved by the Engineer prior to beginning construction.
2. Stabilizing Equipment - All equipment to be approved by the Engineer prior to beginning construction. The stabilizing plant shall be a single-pass, multi-drum, self-propelled rotary mixer combining a cutter rotor, a blending rotor, and two mixing rotors in the mixing chamber. The mixing chamber shall have a positive depth control to insure a uniform depth of stabilized material and must be capable of loosening the base materials to the depth called for without disturbing the subbase. The stabilizing plant shall add the asphalt in predetermined and accurately metered quantities, while maintaining a constant and fixed rate of

forward motion, thoroughly blend the asphalt with the road materials, and spread the mixture uniformly on the roadway.

A spray bar for distribution of the liquid asphalt shall be mounted inside the mixing chamber and shall have nozzles spaced at increments not to exceed six (6) inches and shall operate in such a manner that all asphalt will be uniformly applied throughout the mixing chamber at the time of injection. The asphalt additive system shall consist of a positive displacement pump and shall display the temperature, pressure and flow rate to accurately check the rate of application of the asphalt at any time. Note - Full width processing is required to eliminate longitudinal joints in the stabilizing material necessitating the use of two (2) or more stabilizing machines; depending on the width of road to be processed. The system for distributing the asphalt material shall be adjustable for the rate of asphalt application and shall measure accurately the amount of asphalt material being applied. A foot per minute meter and a gallon per minute meter shall be in clear view of the operator and both shall be controlled by the operator from the operator's station.

CONSTRUCTION METHODS

1. Mixing with Asphalt Materials - Prior to adding the asphaltic material, the moisture content of the crushed material shall be adjusted by aerating or by adding water. The asphaltic material shall be added only to that material which can be completely mixed and compacted in one day. The asphaltic material shall be added through the mixer at the rate and within the temperature range directed by the Engineer. The temperature shall be kept below the flash point of the asphalt cement but shall not fall below 350° F. The mixed material shall be laid directly from the multi-drum mixer to the surface. Conveying the mixed material by belt system from drum to surface will not be allowed.
2. Shaping, Rolling and Compacting - Shaping and compacting shall be done while the asphalt material is in a workable state. The final shaping and compaction shall be accomplished as soon as possible after addition of the asphaltic material. The mixed material shall be so shaped that when compacted it shall be in a reasonably close conformity with lines, grades, and cross-sections shown on the plans or as directed by the Engineer. Stabilized material trimmed from the grade shall be used adjacent to the shoulder to complete the cross section as shown on the plans. Material in excess of the quantity required to complete the cross section shall become the property of the Contractor.

Initial rolling shall be done with one or more pneumatic-tired rollers. The aggregate-asphalt mixture shall be compacted to not less than 98 percent of the unit weight obtained by the Michigan Modified T 180 Test as described in the Density Control Handbook. Such test shall be made on the aggregate-asphalt mixture at the filled moisture content existing during the compacting operation. Required density shall be maintained until the material has been surfaced. Density testing requirements are hereby waived for this project, but may be used, as directed by the Engineer, to assure density is being maintained. After final rolling, the Engineer will test the surface using a 10-foot straightedge at selected locations. The variation of the surface from the testing edge of the straightedge between any two contacts with the surface shall at no point exceed $\pm\frac{3}{8}$ inch.

3. Curing - The base may be opened to traffic for a period of time to be determined by the Engineer prior to placing of the surface. Any areas which show evidence of cracking or instability will be investigated and corrected within 48 hours, before any work proceeds. If the stabilized asphalt aggregate pavement is to be left unsurfaced for more than seven (7) days, a fog coat of SS-1H shall be applied at the rate of 0.20 to 0.30 gallons per square yard, at the Contractor's expense.
4. Weather Limitations - Asphaltic material shall not be applied to the grade or to the aggregate when rain is threatening or when the air temperature is lower than 50° F.

The Stabilization work shall be performed in the Lower Peninsula during the period May 15 to October 15, and in the Upper Peninsula during the period June 1 to October 1, unless otherwise authorized by the Engineer.

MEASUREMENT AND PAYMENT

The completed work as measured for asphaltic stabilized aggregate base course will be paid for at the contract unit prices for the following contract items (Pay Items).

<u>Pay Item</u>	<u>Pay Unit</u>
Asphalt Cement Stabilized Base Course, 4 Inch	Square Yard
Asphalt Cement Binder	Gallon

Payment for Asphalt Cement Stabilized Base Course, 4 Inch includes the furnishing, hauling, placing, mixing of the asphalt cement into the crushed base material, shaping, and compacting of the mixture. This item will be measured by completed width and length required in the plans to a maximum depth of four (4) inches.

Payment for Asphalt Cement Binder shall be paid for by the gallon applied to the base course.

4 OF 4

Payment for Asphalt Emulsion Fog coat SS-1H will not be paid for separately but will be included as part of the work of Asphalt Cement Stabilized Base Course.

Any aerating or adding water necessary to achieve proper moisture will not be paid for separately but will be included as part of the work of Asphalt Cement Stabilized Base Course.

CITY OF OWOSSO
SPECIAL PROVISION
FOR
CONCRETE PAY ITEMS

City of Owosso/RC

1 OF 1

August, 2020

a, Description. This work shall be done in accordance with sections 601 and 701 of the MDOT 2012 Standard Specifications for Construction, except as modified herein. This special provision indicates the type of concrete mixture to be used for pay items related to curb and gutter, drive approaches, and sidewalks.

b. Materials. Cement content for Concrete, Grades S2 and P1, shall be 564 pounds per cubic yard (6 Sack) for all concrete items, in accordance with Sections 601 and 701 of the MDOT 2012 Standard Specifications for Construction. Concrete mix shall not include fly ash or water reducing agents.

c. Construction. Construction of concrete related items including but not limited to curb and gutter, driveways, sidewalks, ADA ramps shall be done in accordance with the MDOT 2012 Standard Specifications for Construction, or as directed by the Engineer.

d. Measurement and Payment. Payment for the completed work for the various concrete pay items in this contract using a six full sack mix shall be included as part of their individual unit prices.

CITY OF OWOSSO
SPECIAL PROVISION
FOR
CURB AND GUTTER, CONC, DET F4, MODIFIED

City of Owosso/RC/CW

1 OF 1

August, 2020

a. Description. This work shall consist of constructing concrete curb and gutter. Complete this work according to the standard specifications, standard detail in the plans, and this special provision.

b. Materials. The materials shall meet the requirements of the Michigan Department of Transportation (MDOT) 2012 Standard Specifications for Construction, Section 802, for concrete curb and gutter.

c. Construction. Construct concrete curb and gutter according to Section 802 of the MDOT Standard Specifications for Construction and the standard detail in the plans.

d. Measurement and Payment. The completed work, as described, will be measured and paid for at the contract unit price using the following Pay Item:

Pay Item	Pay Unit
Curb and Gutter, Conc, Det F4, Modified.....	Foot

Curb and Gutter, Conc, Det F4, Modified will be measured in place by length per foot and paid for per foot. Payment includes all labor, materials, and equipment to install concrete curb and gutter.

CITY OF OWOSSO
SPECIAL PROVISION
FOR
DRAINAGE STRUCTURE COVER, EJ _____

City of Owosso/CW

1 OF 1

February, 2021

a. Description. Drainage Structure Cover EJ _____, shall consist of materials and work meeting requirements of Section 403 of the MDOT 2012 Standard Specifications for Construction, and as modified herein.

b. Materials. All covers will be manufactured and supplied by East Jordan Iron Works. Cover types shall match with the pay item cover number.

d. Measurement and Payment. The completed work as measured for Drainage Structure Cover EJ _____ will be paid for at the Contract Unit Price for the following Pay Item:

Pay Item	Pay Unit
Drainage Structure Cover, EJ 1040 w/ Solid Gasket Sealed Cover.....	Each
Drainage Structure Cover, EJ 1040 w/ Vented Cover.....	Each
Drainage Structure Cover, EJ 1040 w/ Type O2 Beehive Grate.....	Each
Drainage Structure Cover, EJ 7000.....	Each

Drainage Structure Cover, EJ _____ will be measured in place by count of Each; and will be paid for at the contract unit price per Each, which price shall be payment in full for all labor, material, and equipment needed to accomplish this work.

CITY OF OWOSSO
SPECIAL PROVISION
FOR
Dr Structure, __ inch dia, Modified

City of Owosso/CW

1 of 2

March, 2020

a. Description. The Contractor shall construct **Dr Structure, __ inch dia, Modified** of the size and at the locations as shown on the plans or as directed by the Engineer. Work shall be in accordance with Section 403 & 913 of the Michigan Department of Transportation (MDOT) 2012 Standard Specifications for Construction, or as modified herein.

b. Materials. Drainage Structures shall be precast reinforced concrete units manufactured to American Society for Testing Materials (ASTM) C-478 specifications and Section 913 of the Michigan Department of Transportation (MDOT) 2012 Standard Specifications for Construction, with either a cast in place bottom or precast concrete base as detailed on the plans.

The Contractor shall place the drainage structure cover as shown on the plans or as directed by the Engineer.

Provide 4"-12" adjustment area (chimney) above the structure's cone.

Masonry structures will not be allowed to be used on this project, unless approved by the Engineer for special circumstances, or where specifically called for on the Plans.

Thirty-six inch diameter drainage structures (catch basins or inlets) will be allowed to be used on this project, where called for on the plans or where directed by the Engineer.

The Contractor shall provide flexible connectors meeting ASTM C-923 requirements and 'as manufactured' by:

1. Trelleborg - Kor-N-Seal 106-406 and 206 series or approved equal.
2. Press-Seal Corporation's – Direct Drive
3. A-Lok Products, INC. – A-LOK or Z-LOK Connector

c. Measurement and Payment. The completed work as measured for **Dr Structure, __ inch dia, Modified** will be paid for at the contract unit price for the following contract item (pay item).

Contract Item (Pay Item)	Pay Unit
Dr Structure, __ inch dia, Modified.....	Each

The work of **Dr Structure, __ inch dia, Modified** includes the concrete footing, and up to 8' of drainage structure depth. The unit price for **Dr Structure, __ inch dia, Modified** includes the cost of temporary or final grade adjustments of the structure. **Dr Structure, __ inch dia, Modified** will be measured by the unit each and will be paid for at the contract unit price per each, which price shall be payment in full for all labor, material, and equipment necessary to accomplish this work.

If during construction, due to utility conflicts or plan revisions, modifications are required to the piping connection holes or additional taps are required to precast concrete sections, this work will be paid for separately, in the Pay Item for the **Dr Structure, Tap, inch**.

CITY OF OWOSSO
SPECIAL PROVISION
FOR
GEOTEXTILE, SEPARATOR, MODIFIED

City of Owosso/CW

1 of 1

June, 2021

a. Description. The work of **Geotextile, Separator, Modified** shall consist of furnishing and placing woven geotextile on prepared subgrade. Work shall be in accordance with Section 308 of the Michigan Department of Transportation (MDOT) 2012 Standard Specifications for Construction, or as modified herein.

b. Materials. Geotextile, Separator, Modified shall meet or exceed products as manufactured by Mirafi 550X, US Fabrics US 270, ADS 315W, or approved equal.

d. Measurement and Payment. The completed work as measured for **Geotextile, Seperator, Modified** will be paid for at the contract unit price for the following contract item (pay item).

Contract Item (Pay Item)

Pay Unit

Geotextile, Separator, ModifiedSquare Yard

The work of **Geotextile, Separator, Modified** will be measured in place by area in square yards and will be paid for at the contract unit price per square yard which price shall be payment in full for all labor, material, and equipment necessary to accomplish this work. Overlaps, cutting, and fitting of Geotextile, Separator, Modified will not be measured and paid for separately, but are considered included as part of the in-place area measure of the Geotextile, Separator, Modified.

**SPECIAL PROVISION
FOR
HMA BASE CRUSHING AND SHAPING, MODIFIED**

CITY OF OWOSSO/CW

1 OF 1

February, 2021

DESCRIPTION:

All work shall consist of crushing and shaping the existing pavement section and gravel base to the depth and width as shown on the plans, or as directed by the Engineer, in accordance with Sections 305 and 501 of the Michigan Department of Transportation (MDOT) 2012 Standard Specifications for Construction and as modified herein.

CONSTRUCTION:

Crush and shape HMA and gravel base at a depth of 6 inches. Use a water sprinkling system as approved by the Engineer. After crushing, 100 percent (100%) of the crushed material shall have a maximum particle size of 1-½ inches (1.5"). Particles exceeding 1-½ inches shall be removed by the Contractor at the Contractors expense. The crushed material shall be initially shaped immediately after the crushing operation to established grade and cross section within a tolerance of ¾ inches and be opened to local traffic at end of same workday. Sufficient material shall be graded along edges (wind rowed) for final grading and blending shoulder after HMA placement. The crushed surface shall be left to cure in place for a period of time not exceeding three calendar days.

Rolling equipment shall be furnished in accordance with Section 501.03, except that combination of pneumatic tired (1 minimum) and steel vibratory (2 minimum) rollers will be used to properly compact the crushed material to achieve density requirements of Section 305.

MEASUREMENT AND PAYMENT:

The completed work as measured for the following Pay Items will be paid for at the Contract Unit Price for the following Contract Item (Pay Item):

Contract Item (Pay Item)	Pay Unit
HMA Base Crushing and Shaping, Modified	Square Yard

HMA Base Crushing and Shaping, Modified will be measured in area by square yard; and will be paid for at the contract unit price per square yard, which price shall be payment in full for all labor, material, and equipment needed to accomplish this work. Shaping includes initial, intermediate, and final shaping of the prepared crushed material.

The Department shall pay separately for additional aggregate as Aggregate Base, LM, Modified if additional aggregate is needed to construct the proposed cross section.

MICHIGAN
DEPARTMENT OF TRANSPORTATION

SPECIAL PROVISION
FOR
TEMPORARY PEDESTRIAN TYPE II BARRICADE

OFS:RAL

1 of 2

APPR:CAL:CT:08-02-16

a. Description. This work consists of furnishing, installing, maintaining, relocating, and removing a temporary pedestrian Type II barricade section as identified in the proposal or on the plans. Use temporary pedestrian Type II barricades to close non-motorized facilities including sidewalks, bicycle paths, pedestrian paths, and shared use paths that are not part of the roadway. One pedestrian Type II barricade is defined as a barricade section at least 43 inches wide, including all supports, ballast, and hardware.

b. Materials. Provide a temporary pedestrian Type II barricade that meets the requirements of *National Cooperative Highway Research Program Report 350 (NCHRP 350)* or *Manual for Assessing Safety Hardware (MASH)*, in addition to meeting the following requirements:

1. Provide barricade sections at least 43 inches wide, designed to interconnect to ensure a continuous *Americans with Disabilities Act (ADA)* compliant tactile barrier. Ensure the connection includes provisions to accommodate non-linear alignment as well as variations in elevation at the installation area.

2. Ensure the top surface of the barricade is designed to function as a hand-trailing edge, and has a height between 32 and 38 inches. Ensure the lower edge of the barricade is no more than 2 inches above the surface of the non-motorized facility. Ensure the top edge of the bottom rail of the barricade is a minimum of 8 inches above the surface of the non-motorized facility. The barricade may have a solid continuous face. Finally, all features on the front face of the barricade (the face in contact with pedestrians) must share a common vertical plane.

3. Equip both sides of the barricade with bands of alternating 6-inch wide orange and white vertical stripes of reflective sheeting. Two bands of sheeting 6 inches tall and a minimum of 36 inches long containing at least two orange and two white stripes each are required. One band placed near the top and one near the bottom if the barricade section has a solid face. If the barricade consists of two rails, affix one band of sheeting to each rail. Ensure the stripes of reflective sheeting are aligned vertically. Ensure this sheeting meets or exceeds the requirements of *ASTM D 4956* Type IV sheeting.

c. Construction. Construct the temporary pedestrian Type II barricade in accordance with the manufacturer's recommendations, Michigan Manual on Uniform Traffic Control Devices (MMUTCD), the plans, and the following requirements:

1. Install the barricade as shown on the plans and as directed by the Engineer. Interconnect all barricade sections using hinge components if necessary to ensure a continuous detectable edge for the entire installation. Ensure the barricade is ballasted according to the manufacturer's recommendations to ensure stability during wind events and contact with pedestrians.

2. When the barricade is installed near motor vehicle traffic, ensure reflective sheeting is visible to motorists.

3. When pedestrian Type II barricades are used to close a non-motorized facility, ensure a sufficient number of barricade sections are used to block the entire width of the facility. The barricade may extend outside the edge of the non-motorized facility but must not be less than the full width of the facility.

4. If sections of multiple colored barriers are used (i.e. safety orange and white) install the sections such that the colors alternate to increase conspicuity.

5. Ensure pedestrian Type II barricades are not used to close a motor vehicle facility. Ensure these barricades are not used to guide pedestrian traffic on a motor vehicle facility in the presence of active traffic. This prohibition includes bicycle/shared use lanes or shoulders in the presence of active traffic.

d. Measurement and Payment. The completed work, as described, will be measured and paid for at the contract unit price using the following pay item:

Pay Item	Pay Unit
Pedestrian Type II Barricade, Temp	Each

Pedestrian Type II Barricade, Temp, includes all labor, equipment, and materials to furnish, install, maintain, relocate, and remove one barricade section that is at least 43 inches wide. Additional payment will not be made if wider sections are provided. This includes all rails, supports, ballast, hinge points, reflective sheeting, and miscellaneous hardware needed to install and maintain a barricade section.

CITY OF OWOSSO
SPECIAL PROVISION
FOR
SANITARY SERVICE, CONFLICT

City of Owosso/RC

1 OF 1

August, 2020

a. Description. The work of Sanitary Service, Conflict consists of relocating (lowering) existing sanitary service connections that conflict with proposed storm sewer installation as shown on the plans or as directed by the Engineer. The work must be coordinated with City of Owosso DPW officials.

b. Materials. The materials for relocating existing sanitary sewer service connections shall consist of new material meeting the requirements of the City of Owosso. City DPW officials will review with the Contractor the type of material found, then determine suitable new material and adaptors required to reconnect the sanitary service.

c. Construction. The City of Owosso will be responsible for temporarily shutting off the wastewater system. The Contractor shall cooperate with City of Owosso DPW officials in establishing service relocation, material selection, and work method in order to reroute the sanitary service under the proposed storm sewer. The entire crossing area shall be filled with 6A compacted crushed stone, from bottom of pipe to one foot above top of pipe. A geotextile separator shall be laid on top the stone backfill. Granular Material, Class II shall be placed and compacted from the geotextile separator to plan grade.

d. Measurement and Payment. The completed as measured for Sanitary Service, Conflict will be paid for at the Contract Unit Price for the following Pay Item:

Pay Item	Pay Unit
Sanitary Service, Conflict.....	Each

Sanitary Service, Conflict will be measured in place by the unit Each; and will be paid for at the contract unit price per Each, which price shall be payment in full for all labor, material, and equipment needed to accomplish this work.

CITY OF OWOSSO
SPECIAL PROVISION FOR
SEWER, SDR-26, __ inch, Tr Det __, Modified
SEWER, SDR-26, __ inch, Tr Det __, Insulated, Modified

City of Owosso/RC

1 of 1

February, 2021

a. Description. The work of Sewer, SDR-26, _ inch, Tr Det __, Modified, shall consist of excavation, furnishing and placing plastic sewer pipe, and trench backfill, in accordance with section 402 of the Michigan Department of Transportation (MDOT) 2012 Standard Specifications for Construction, Michigan Department of Transportation Standard Plan R-83 series and the details within the construction plans, except as modified herein.

b. Materials. Materials for sewer pipe shall meet or exceed ASTM D-3034 SDR-26 or ASTM D-2241 SDR-26 specifications for PVC integral gasket sewer pipe, depending on pipe diameter. Material for backfill shall be in accordance with the details within the standard plan R-83 series.

When called for on the plans, Type IV Styrofoam Brand - "Square Edge" or "Score Edge" as manufactured by Dupont/Dow Chemical Company or approved equal shall be used for insulating sewer pipes. The total thickness and dimensions shall be specified on the plans or in the Specifications. The minimum insulation thickness however shall not be less than 4 inches.

c. Construction. The extensions/connections to existing culverts/sewers on this project will require a FERNCO coupler to obtain a tight seal at the joint connecting new pipe to existing pipe. The joint between the existing and new pipes shall be constructed according to the 2012 MDOT Standard Specifications for Construction and as directed by the Engineer. Any extra work required to obtain tight joints will not be paid for separately but will be included in compensation for new pipe. Sewer trench shall meet requirements of Trench Detail B, Modified, as shown on the plans.

d. Measurement and Payment. The completed work as measured for Sewer, SDR-26, _ inch, Tr Det __, Modified and Sewer, SDR-26, __ inch, Tr Det __, Insulated, Modified will be paid for at the contract unit price for the following contract item (pay item).

Contract Item (Pay Item)	Pay Unit
Sewer, SDR-26, _ inch, Tr Det __, Modified	Foot
Sewer, SDR-26, _ inch, Tr Det __, Insulated, Modified	Foot

Sewer, SDR-26, _ inch, Tr Det __, Modified and Sewer, SDR-26, _ inch, Tr Det __, Insulated, Modified will be measured in place by length in feet and will be paid for at the contract unit price per foot which price shall be payment in full for any Fernco fittings, connecting to existing sewers, neoprene gaskets, couplers, sheeting or shoring trench walls, backfill as required and all labor, material and equipment needed to accomplish this work.

CITY OF OWOSSO
SPECIAL PROVISION
FOR
SUBGRADE UNDERCUTTING, SPECIAL

City of Owosso/CW

1 of 2

June, 2021

a. Description. The work of Subgrade Undercutting, Special shall consist of Subgrade undercutting and backfilling with Structural Geogrid and 12 inches of Michigan Class 21AA crushed limestone aggregate. This work shall be performed in accordance with Section 205 of the Michigan Department of Transportation (MDOT) 2012 Standard Specifications for Construction unless modified by this Special Provision or otherwise directed by the Engineer.

1. Definitions and References:

A. Structural Geogrid. A Structural Geogrid is formed by a regular network of integrally connected tensile elements with apertures of sufficient size to allow interlocking with surrounding soil, rock, or earth, and function primarily as reinforcement.

B. Geosynthetic Research Institute:

GG1-87 Standard Test Method for Geogrid Rib Tensile Strength

GG2-87 Standard Test Method for Geogrid Junction Strength

b. Materials.

1. Structural Geogrid shall be as manufactured by Tensar Earth Technologies, Inc. (Structural Geogrid BX1100 or BX1120) or Geostar Technologies (GB11), or approved equal.

2. Backfill shall be Michigan Class 21AA crushed limestone aggregate in accordance with Section 902 of the MDOT 2012 Standard Specifications for Construction.

c. Methods of Construction. The Subgrade shall be undercut a uniform 12 inches.

1. Structural Geogrid Storage and Installation. The Structural Geogrid shall be laid horizontally on the prepared subgrade and pulled taut and anchored prior to backfill placement. At longitudinal and transverse edges, the Structural Geogrid shall be overlapped a minimum of 12 inches.

Rolled Structural Geogrid may be laid flat or stood on end and shall be stored at temperatures above -20 Degrees F (-29 Degrees C). The Structural Geogrid shall be protected from excessive mud, wet cement, epoxy, and other deleterious like materials.

2. Backfill Placement. Backfill shall be placed, spread, and compacted via a method that minimizes the development of slack in the Structural Geogrid. Backfill shall be placed and compacted in accordance with Section 302 of the MDOT 2012 Standard Specifications for Construction.

3. General. Tracked construction equipment shall not be operated directly on the Structural Geogrid. A minimum fill thickness of 6 inches is required prior to operation of tracked vehicles over the Structural Geogrid. Turning of tracked vehicles should be kept to a minimum to prevent tracks from displacing the fill and damaging the Structural Geogrid.

d. Measurement and Payment.

Contract Item (Pay Item)

Pay Unit

Subgrade Undercutting, Special.....Square Yard

The completed work for **Subgrade Undercutting, Special** will be measured in place by area in square yards. Payment for **Subgrade Undercutting, Special** will include furnishing all labor, equipment, and materials required to excavate and dispose of the unsuitable material, furnishing and placing the Structural Geogrid and backfilling with 21AA crushed limestone aggregate.

**SPECIAL PROVISION
FOR
TRENCHING, MODIFIED**

CITY OF OWOSSO/RC

1 OF 1

October, 2018

DESCRIPTION:

This work item shall consist of trenching either one or both sides of the existing pavement section so as to accommodate the widening for proposed pavement, to the depth as shown on the plans, or as directed by the Engineer. All work shall be done in accordance with Section 307 of the Michigan Department of Transportation (MDOT) 2012 Specifications for Construction and as modified herein.

METHOD OF CONSTRUCTION

The Contractor shall trench along the existing pavement edge at varying widths and varying depths as shown on the plans. The trench shall be excavated to the proposed width and depth. Any disturbed underlying soil shall be properly compacted, as directed by the Engineer. Some select excavated material may be leveled as embankment on-site, adjacent to the proposed pavement edge, as directed by the Engineer. Excess excavated material shall become responsibility of the Contractor for proper disposal.

METHOD OF MEASUREMENT AND PAYMENT

The completed work as measured for Trenching, Modified will be paid for at the Contract Unit Price for the following Contract Item (Pay Item).

CONTRACT ITEM (Pay Item)

Pay Unit

Trenching, Modified

Station

Trenching, Modified will be measured in length by stations; separately along each side of existing pavement; and will be paid for at the Contract unit price per station, which price shall be payment in full for all labor, material, and equipment needed to accomplish this work. Disposal of all excess material is included as part of the pay item Trenching, Modified.

MICHIGAN
DEPARTMENT OF TRANSPORTATION

SPECIAL PROVISION
FOR
TURF ESTABLISHMENT, PERFORMANCE

RSD:JLB

1 of 6

APPR:DMG:KJS:05-13-20

a. Description. For the work specified in this special provision paid for by the pay item Turf Establishment, Performance only, delete section 816 of the Standard Specifications for Construction and replace it with this special provision. The Contractor is responsible for the performance and quality of turf growth in the areas shown on the plans and as identified by the Engineer. Comply with all local, state and federal laws when completing this work.

Establish a durable, permanent, mature, perennial turf. The work consists of fundamental turf work, including but not limited to topsoiling, seeding, mulching, erosion control, maintenance, watering and repair of turf as described herein during the life of the contract and during the life of any supplemental performance bond which may ensue.

Choose and implement proven turf establishment industry practices; provide all necessary labor and equipment; select and provide all turf establishment materials; and control erosion and any subsequent sedimentation at all times.

Perform a site analysis, interpret the results and implement a turf establishment program to ensure compliance with this specification. The site analysis must take into consideration topsoil needs, fertilizer and pH requirements, seed mix, existing and future soil moisture levels, slopes and grades, required erosion control measures, maintenance requirements, local highway snow removal and deicing practices, and any other characteristics that influence and affect turf establishment.

Subsection 107.11 of the Standard Specifications for Construction is revised relative to the Contractor's responsibility for the repair of turf establishment work as follows. The Contractor is responsible, at no additional cost to the contract, for the repair of turf establishment work occasioned by storm events up to 3 inches of rain in a 24 hour period as documented by local meteorological data submitted to the Engineer for review and approval. All other portions of subsection 107.11 remain unchanged.

1. Contractor Turf Establishment Experience Requirements. Ensure weed control is done by a commercial herbicide applicator, licensed by the State of Michigan and certified by the Michigan Department of Agriculture & Rural Development (MDARD) in the appropriate category to apply herbicides. Use application procedures and materials in accordance with federal, state and local regulations. Use of restricted use chemicals is prohibited. Provide appropriate documentation and secure approval from the Engineer before application of herbicides.

At least 10 work days prior to the start of turf establishment, provide documentation to the Engineer, from the Contractor performing the turf establishment work, that they meet one or both of the following requirements.

A. At least one person employed by the Contractor performing the turf establishment work and assigned to the job site has a degree or certificate in Turf Management, Horticulture or related field.

B. At least one person employed by the Contractor performing the turf establishment work and assigned to the job site has at least 5 years of experience in roadside turf establishment.

b. Materials. Provide topsoil, seed, mulch, pesticide, herbicide, mulch blanket and any other unique erosion control materials as necessary to fulfill this specification, as shown on the plans. Use additional materials, as necessary, to meet the standards set forth for turf establishment in this special provision. The use of sod on the project requires the prior approval of the Engineer and if approved, may be used at limited site locations only.

Selection of all materials is the responsibility of the Contractor with the following minimum conditions.

1. Soil. Provide furnished or salvaged topsoil, which may be blended compost, that will support vigorous growth. Ensure topsoil is humus bearing and placed at least 4 inches deep. Ensure it is free of stones larger than 1/2 inch (2 inches on freeway projects) in diameter and other debris. Trim and grade the finished slope in accordance with subsection 205.03.N of the Standard Specifications for Construction.

2. Seed. Use a seeding mixture that is composed of four or more species of perennial grass. Use only species and their cultivars or varieties which are guaranteed hardy for Michigan.

Recommended species of perennial grasses include Kentucky Bluegrass, Perennial Ryegrass, Hard Fescue, Creeping Red Fescue, Chewings Fescue, Turf-type Tall Fescue, Buffalo grass, and Alkaligrass-Fulfs Puccinellia distans. Select cultivars or varieties of grasses that are disease and insect resistant and of good color. Ensure that no one species in the mix is less than 5 percent, or more than 25 percent, of the mixture by weight. Do not select grass species considered noxious or objectionable, such as Quack Grass, Smooth Brome, Orchard Grass, Reed Canary Grass and others.

A. Ensure the seed is legally saleable in Michigan. Ensure the seed product does not contain more than 10 percent inert materials. Ensure the seed source is an MDOT approved certified vender.

B. Adapt the species and varieties of seed to the site conditions, to the site use, and to the soils, moisture and local climate. Site use may include, but is not limited to, detention pond, wildlife habitat, playground, wetlands, forested wetland, rural roadside, urban roadside and highly maintained front yard.

C. Ensure at least two of the species in the mixture proposed to be planted within 15 feet behind the curb or the shoulder are salt tolerant.

3. Mulch. Mulch seeded areas with the appropriate materials for the site conditions to promote germination and growth of seed and to mitigate soil erosion and sedimentation.

4. Herbicides. Comply with all federal, state and local laws. As part of the MDARD weed

control application, the Contractor is required to make proper notifications and postings in accordance with the label and MDARD requirements for all locations that will be sprayed. Notify the Engineer at least 48 hours prior to any applications being made. Furnish and apply herbicide(s) as needed. It is the Contractor's responsibility to select the herbicide(s) and the rate at which it is used. Obtain the Engineer's approval of work methods and herbicide(s) selected prior to the application of the herbicide(s). Complete a spray log and submit to the Engineer each day an application is made.

Do not draw water from any waterway (i.e. river, ditch, creek, lake etc.) located on state, county or municipal right-of-way, for mixing with herbicides.

5. Fertilizers. Furnish and apply fertilizer(s) as needed. It is the Contractor's responsibility to select the fertilizer(s) and the rate at which it is used. Phosphorus is allowed for use only at the time of planting and when required by soil conditions. Obtain the Engineer's approval of work methods and fertilizer(s) prior to the application of the fertilizer(s).

6. Water. Furnish and apply water from an approved source at a rate to promote healthy growth.

c. Construction. The Contractor is responsible for all work and all construction methods used in completing this work. Implementation of any part of the standard specifications or standard plans by the Contractor does not relieve the Contractor of responsibility for acceptability of the construction methods or for the quality of the work.

1. Inspection of the Work. The Contractor is responsible for all inspection of turf establishment work.

Use a Contractor's Daily Report, approved by the Engineer, to report inspections made and to document turf establishment work performed on this project. Complete and submit a Contractor's Daily Report to the Engineer when any work performed under this special provision is in progress.

Include all necessary materials documentation including tests slips, certifications, etc. with the associated Contractor's Daily Report.

The Engineer will determine the acceptability of the Contractor's Daily Report in terms of the completeness and accuracy. The Engineer reserves the right to verify all submitted measurements and computations. Failure by the Contractor to submit acceptable and timely reports to the Engineer may result in withholding of progress pay estimates on turf-related items until such time as reports are submitted and deemed acceptable.

The Engineer reserves the right to inspect the project for any reason in accordance with subsection 104.01 of the Standard Specifications for Construction, including the fulfillment of other inspection requirements such as Soil Erosion and Sedimentation Control, NPDES, etc. Inspections made by the Engineer do not relieve the Contractor of the responsibility for inspections required by this special provision or the Contractor's responsibilities for erosion control and turf establishment.

2. Erosion Control. Control erosion at all times in accordance with section 208 of the Standard Specifications for Construction. Control of soil erosion is the responsibility of the Contractor. However, ensure sedimentation controls are placed as shown on the plans or as

directed by the Engineer. Continuously monitor the site for needed erosion repair from any cause as addressed in the contract. Return all eroded areas to original grade as detailed in the contract.

Take immediate corrective action if sedimentation occurs in drainage structures or any watercourse or water containment area and stabilize all disturbed areas contributing to this sedimentation within 24 hours after the erosion occurrence. Remove sediment deposited as a result of the Contractor's inability to control the soil erosion at the Contractor's expense.

Reimburse the Department for any costs levied against the Department, such as fines, environmental costs, costs for remedies required, or any other costs as a result of the Contractor's failure to comply with this special provision and with federal, state and local laws.

3. Erosion Repair. The Contractor is responsible for all repairs and liable for all consequences (legal, monetary or other) associated with erosion or sedimentation damage to finished or unfinished work.

Report all erosion occurrences and the repairs made by the Contractor to the Engineer in the format and at the frequency required by the Engineer. Repair any erosion, displacement or disturbance to ongoing or completed work by any cause at no additional cost to the contract unless otherwise noted herein.

The Contractor is responsible and liable for all traffic control and safety measures required to repair and protect damaged turf areas. Repair any eroded area that may affect the support of the roadbed or safety of the public within 24 hours of the erosion occurrence.

Place protective devices such as barriers, directional signs/signals, temporary fence, or any other safety measures immediately after any erosion damage occurs that has the potential of endangering the public. In these instances, provide the Engineer with a written summary of the immediate action taken describing the repairs made and the safety measures taken, within 24 hours of the occurrence of the damage.

4. Mowing and Weeding. Maintain turf to a visually appealing level, and not more than 8 inches in height at any time, prior to acceptance. Weeds must be controlled to less than 10 percent of the turf establishment area at all times during construction.

5. Final Acceptance and Supplemental Performance Bond.

A. Final Acceptance Parameters. Ensure before final acceptance of the turf establishment work, all of the following minimum parameters are met throughout all exposed areas of the project designated on the plans or identified by the Engineer as turf establishment areas: there must be no exposed bare soil and the turf must be fully germinated, erosion free, weeds less than 10 percent, disease free, dark green in color and in a vigorous growing condition.

The Engineer will notify the Contractor of the dates and times of all acceptance inspections. The Contractor may accompany the Engineer during these inspections. If the Contractor does not agree with the decision made by the Engineer, the Contractor may request an inspection by a mutually agreed upon third party (Michigan State University Extension service or other). A joint inspection, to include the Engineer, the Contractor, and the third party, will be scheduled by the Engineer. Pay all expert fees and

expenses charged by the third party.

B. Supplemental Performance Bond. In the event that all contract items of work are completed, including the placement of all turf establishment items of work, and the final acceptance of the project is delayed because the final acceptance parameters for the turf establishment work have not been fully met; the Contractor may propose to the Engineer the use of a supplemental performance bond.

The bond serves to secure the successful completion of turf establishment work and fulfillment of all final acceptance parameters for the turf establishment work. Ensure the supplemental performance bond, in all respects, is satisfactory and acceptable to the Department and executed by a surety company authorized to do business with the State of Michigan.

Ensure the bond is in an amount equal to 50 percent of the turf establishment work items covered by this special provision. Ensure the bond remains in place for two growing seasons. At the discretion of the Engineer, the bond may be reduced on a prorated basis as portions of the areas designated for turf establishment on the project meet the final acceptance parameters.

Prior to commencement of any work necessary to meet the acceptance parameters during the bonded period, the Contractor must apply for a permit to work within the right-of-way through the [MDOT Permit Gateway](#). The permit fee and an individual permit performance bond will not be required. The permit insurance requirements, however, will be required.

d. **Measurement and Payment.** The completed work, as described, will be measured and paid for at the contract unit price using the following pay item:

Pay Item	Pay Unit
Turf Establishment, Performance	Square Yard

Turf Establishment, Performance includes installing, maintaining, inspecting, repairing and meeting the acceptance parameters for turf establishment specified in this special provision, including preparation, updating and submittal of the Contractor's Daily Reports.

Repairs made to damaged turf establishment areas as a result of a documented storm by local meteorological data resulting in rainfall amounts of more than 3 inches in a 24 hour period will be paid for as an increase to original quantities in accordance with subsection 109.05 of the Standard Specifications for Construction.

The following schedule of payment applies to work performed in accordance with this special provision. Upon completion of topsoil surfacing stage, 50 percent of the authorized amount for **Turf Establishment, Performance** will be paid to the Contractor. The remaining 50 percent of the authorized amount will be paid upon completion of all other work necessary to comply with this special provision and to meet all final acceptance parameters for **Turf Establishment, Performance** or at such time as the supplemental performance bond is accepted by the Department.

The supplemental performance bond and all costs associated with turf establishment work performed during the duration of the performance bond will not be paid for separately. These

costs which may include, but are not limited to, mobilization, traffic control devices, and the required permit insurance are included in the unit price bid for **Turf Establishment, Performance.**